

FROM RESEARCH TO INDUSTRY



Nuclear Energy Division

03

4th-GENERATION SODIUM-COOLED FAST REACTORS

THE ASTRID TECHNOLOGICAL DEMONSTRATOR

DECEMBER 2012

SUSTAINABLE RADIOACTIVE WASTE MANAGEMENT ACT OF JUNE 28, 2006:
RESULTS OF RESEARCH CARRIED OUT ON THE SEPARATION AND
TRANSMUTATION OF LONG-LIVED RADIOACTIVE ELEMENTS, AND ON THE
DEVELOPMENT OF A NEW GENERATION OF NUCLEAR REACTORS

03

4th GENERATION
SODIUM-COOLED
FAST REACTORS

THE ASTRID
TECHNOLOGICAL
DEMONSTRATOR



FOREWORD

The objective of the Generation IV International Forum (GIF), in which France is actively involved, is to prepare the future nuclear sector in an international framework by jointly developing the R&D of 4th generation reactors, based on clearly identified objectives:

- achieve sustainable development of nuclear energy by optimising the use of natural uranium resources and by reaching the highest levels of nuclear safety;
- minimise the production of the most radioactive waste, in particular long-lived waste;
- ensure high resistance to nuclear proliferation;
- develop applications of nuclear energy for other uses than production of electricity.

After an analysis phase carried out jointly by the founding partners, the GIF selected six concepts of nuclear reactors and their cycles⁴ which exhibited the most promising potentials to achieve the abovementioned objectives:

- SFR: Sodium-cooled Fast Reactor;
- GFR: Gas-cooled Fast Reactor;
- LFR: Lead-cooled Fast Reactor;
- SCWR: Supercritical Water-cooled Reactor;
- VHTR: Very High Temperature Reactor;
- MSR: Molten Salt Reactor.

Except for the VHTR, all these systems operate in closed cycle, that is to say that they are based on recycling of reusable materials, in particular plutonium. The first three systems among the six ones are characterised by the fact that they are fast neutron reactors (FR). These are the SFR, GFR and LFR systems which differ by their coolants: sodium for the SFR system, gas for the GFR system and lead for the LFR system.

The SCWR is a reactor whose technology is derived from that of pressurised water reactors (PWR) and it uses a particular coolant: supercritical water. Obtaining a spectrum of fast neutrons in such a concept involves significant difficulties (thermal hydraulics, coupling with the neutronic systems and stability of the reactor) and most of the studies performed on the SCWR within the GIF are now focused on a version with thermal neutron spectrum.

MSR will appear in a more distant future and, in theory, they can be derived into versions operating in fast or thermal spectrum.

Finally, VHTR is a thermal spectrum system. The specificity of this concept lies in its high temperature operation (up to 1,000°C for the coolant) for applications other than the production of electricity.

Therefore, among the six concepts selected by the GIF, only four will or can operate in fast neutron spectrum (SFR, GFR, LFR and MSR) and have intrinsic characteristics (associated with a closed fuel cycle) suitable for sustainable development of nuclear energy.

EUROPE'S CHOICES

European countries are currently maintaining very different positions concerning the part that the nuclear sector must play in their energy mix, whether in the medium or the long run. However, several European countries and the European Commission have recognised that nuclear energy will necessarily play a significant part in the way of responding to the energy demand in a context of greenhouse gas reduction. The SET Plan⁵, proposed by the European Commission in November 2007 and adopted by the European Union Member States in February 2008, considers that it is essential to start, within the next ten years, the construction of a new-generation reactor demonstrator for sustainable nuclear energy. Although certain countries have decided to stop using nuclear energy, the Fukushima accident does not throw back into question the fundamental elements expressed in the SET Plan.

The European nuclear technology development sector, gathered in the SNETP⁶ platform, defined its strategy and priorities in its "Vision Report" published in September 2007 and detailed in its "Strategic Research Agenda" published in May 2009: nuclear fission will bring a massive, carbon-free and sustainable contribution to the European energy mix by relying on fast neutron reactors (FR). The SFR technology is considered as the reference system, while two alternatives will have to be explored in the long run: the GFR and LFR technologies:

In line with the recommendations of the SET Plan, the SNETP platform launched the ESNII (European Sustainable Nuclear Industrial Initiative), which gathers industrialists and R&D organisations around this action plan.

4 – A Technology Roadmap for Generation IV Nuclear Energy Systems, December 2002 - US-DoE and GIF.

5 – SET Plan: Strategic Energy Technology Plan http://ec.europa.eu/energy/technology/set_plan/set_plan_en.htm

6 – Sustainable Nuclear Energy Technology Platform. www.snetp.eu

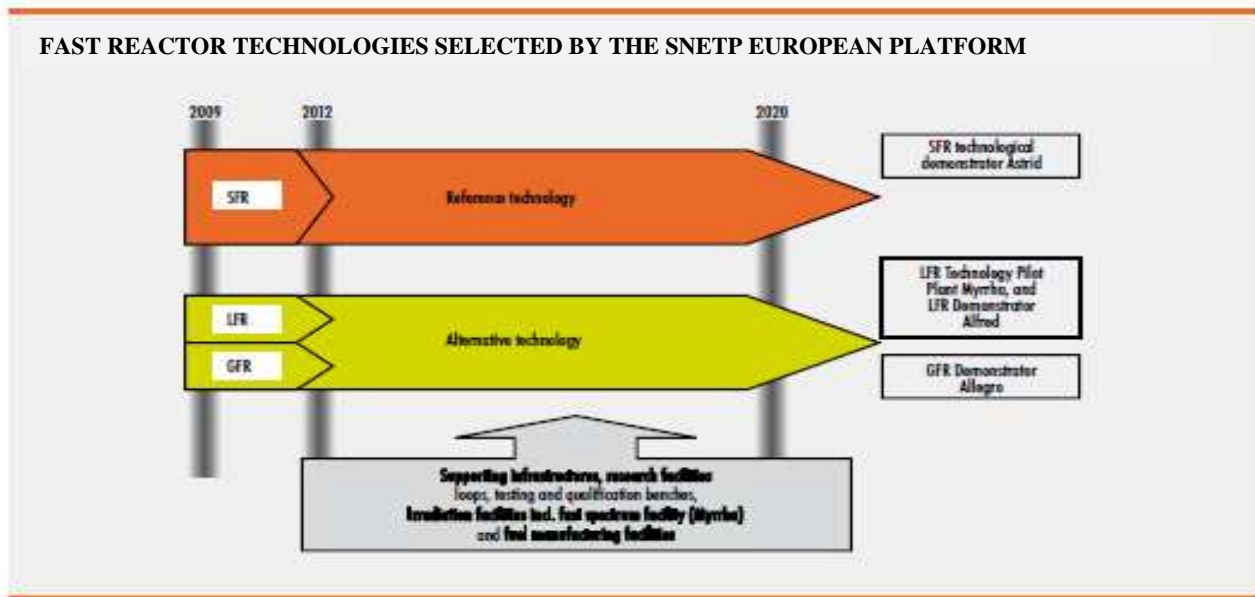

FRANCE'S POSITION

France has joined the European strategy. The more specific analysis carried out in France led to the following conclusions:

- France has brought a major contribution to the development of SFRs and intends to rely on its large experience to develop this system with the purpose of achieving the allocated objectives. Furthermore, this experience is a significant heritage of intellectual property and provides our country and its industrialists with a competitive advantage.
- There is a strong connection between the technological maturity of a process and nuclear safety. As a matter of fact, technological control associated with significant experience feedback contributes to guaranteeing the safety level of a system. Therefore, among the 4th generation fast reactor systems, only the SFR has a sufficient knowledge base to meet the technical and operational expectations of 4th generation systems in the short and medium runs. The economic conditions of the development of such systems still remain to be assessed. They will have to be examined in the overall context of a fleet in which, at the beginning, 3rd and 4th generation reactors will be used simultaneously in order to produce electricity at the best price while fulfilling a strategy intended to implement sustainable management of radioactive waste produced by used fuels based on the concept of closed cycle applied in its entirety. The other systems involve much more significant uncertainties, as some major technological obstacles still have not been cleared.
- The GFR system is highly attractive since the use of coolant gas, in particular helium, removes the difficulties related to the use of a liquid metal such as sodium or lead:
 - Helium is optically transparent, unlike liquid metals; this makes in-service inspection and repairability easier;
 - Helium is chemically inert, contrary to sodium which reacts with air and water;
 - Helium has a very low neutral impact; in case of loss of coolant, the resulting reactivity effect is very small.
- On the other hand, gas has drawbacks:
 - Its low density and low calorific value require the use of a pressurised primary circuit. During an accident leading to a loss of the coolant, the thermal inertia of the reactor will be very limited in comparison to the inertia of liquid metal cooled reactors. As a matter of fact, the decay heat removal capacity and the associated safety demonstration still remain a significant problem for the demonstration of feasibility of GFRs, in particular with the post-Fukushima type requirements;
 - In order to have a sufficient margin in terms of core integrity as a measure for prevention of severe accidents, it is necessary to use a fuel and refractory cladding and structure materials able to withstand high temperatures. This is also a technological obstacle that still remains to be cleared;
 - Gas has a lower heat extraction capability, which requires to reduce the power density of the core by a factor of 2 to 3 in comparison to the power density of liquid metal cooled fast reactors; this means drawbacks in terms of saving, as it requires a significant quantity of fuel.

- The main advantage of the lead coolant in comparison to sodium is its low chemical reactivity with air and water. The main drawbacks of lead are its toxicity, its temperature ranges (risk of blockage due to freezing of the lead), and its density which is detrimental to the resistance of the reactor in case of earthquake. But the main technological obstacle of lead concerns the development of structure materials able to resist lead corrosion.
- Finally, in its principle, MSR is an interesting concept since the fuel is in a liquid form mixed with the coolant. The number of technological obstacles to be cleared is such that this type of system will certainly not be able to enter service before the second half of this century, in particular given the quantity of innovations to be achieved to comply with the safety objectives considered. Beyond the questions related to on-line fuel reprocessing, materials able to withstand salt corrosion need to be designed and developed. The safety approach also has to be entirely redefined since there is no cladding to contain the fuel, the first barrier being relocated at the limits of the primary system. It is not to be noted that a tricky and unusual point of the overall safety approach concerns the aspects related, on the one hand, to the nuclear reactor and, on the other hand, to the plant used for chemical processing of the fuel and molten salt mixture. There are also many operability-related questions (in particular inspection

and repair in the presence of highly radioactive salts). It is to be noted that the operation and safety of an MSR strongly depend on chemical processes whose control is very complex and which are still poorly known, thus leading to risks of leakage. Another problem concerns the coupling of these chemical processes with the neutron equipment of the core or with the mechanisms of degradation of materials under irradiation. The CNRS is performing the main part of the studies on MSR in France. Within the GIF, this concept is currently studied and supported only by France and Euratom, through a “Memorandum of Understanding” (MoU), and the “system” agreement still remains to be negotiated.

During the Committee on Atomic Energy of 17 March 2005 concerning future nuclear systems, the Ministers for Industry and Research acknowledged the fact that, in the current state of knowledge, there is a very broad international consensus on the fast reactor technology and they recommended that research in France should be carried out in priority for two types of reactors: SFR and GFR.

This position was confirmed and consolidated during the Committee on Atomic Energy of 20 December 2006.

The SFR reference system is specifically dealt with in Tome 3. Tome 4 is dedicated to the other 4th generation fast neutron systems: GFR, LFR and MSR.

CONTENTS

1.	INTRODUCTION.....	10
-----------	--------------------------	-----------

2.	EXPERIENCE FEEDBACK OF FAST REACTORS IN FRANCE AND WORLDWIDE	13
2.1.	Results of the operation of fast reactors worldwide.....	13
2.2.	Summary of experience feedback in various fields	13
2.2.1.	Experience acquired and intrinsic advantages.....	13
2.2.2.	Specific difficulties or problems	14

3.	PRIORITY IMPROVEMENT AREAS AND ASSOCIATED R&D PROGRESS	19
3.1.	Reactor safety.....	19
3.1.1.	Prevention of severe accidents	19
3.1.2.	Mitigation of severe accidents	23
3.1.3.	Sodium-water risk: power conversion system	25
3.1.4.	Sodium leak detection	28
3.2.	Higher availability than former SFRs and reduced shutdown times.....	28
3.2.1.	Instrumentation and inspection, monitoring and repairability	28
3.2.2.	Fuel subassembly handling and cleaning.....	29

4.	SPECIFICATIONS AND SAFETY OBJECTIVES OF ASTRID.....	33
4.1.	Astrid specifications.....	33
4.2.	General safety objectives	33
4.3.	General safety orientations.....	34
4.4.	Safety orientations in the design phase	34
4.5.	Integration of internal and external hazards	35
4.6.	Orientations taken to ensure the safety functions	35
4.6.1.	“Reactivity control” function	35
4.6.2.	“Cooling control” function	36
4.6.3.	“Radiological containment control” function	36
4.7.	Orientations regarding severe accidents	36

5.

REQUIREMENTS TO BE COMPLIED WITH AND BASIC CHOICES FOR ASTRID	39
5.1. Strategic requirements	39
5.1.1. Astrid's power	39
5.1.2. Astrid's potential of transmutation demonstration	39
5.1.3. Astrid's experimental potential	41
5.1.4. Resistance to proliferation	41
5.2. Safety requirements.....	42
5.2.1. Prevention and mitigation of severe accidents	42
5.2.2. Decay heat removal	42
5.2.3. Presence of a molten core catcher	42
5.2.4. Inspectability of structures	42
5.2.5. Sodium risks	42
5.3. Security requirements	43
5.4. Operating requirements.....	43

6.

ASTRID DESIGN OPTIONS FOR MAJOR FIELDS	45
6.1. Core and fuel	45
6.1.1. Fuel material	45
6.1.2. Cladding material	45
6.1.3. Fuel element	45
6.1.4. Core and subassemblies	46
6.2. Nuclear island	47
6.2.1. Principle of "clean" primary circuit	47
6.2.2. Pool type primary circuit	47
6.2.3. Presence of an intermediate circuit	47
6.2.4. Internal architecture of the primary circuit	47
6.2.5. Core supporting structures	50
6.2.6. Reactor block closing slab	50
6.2.7. Neutron monitoring	50
6.2.8. Molten core catcher	50
6.2.9. Decay heat removal	51
6.2.10. Intermediate sodium loops	51
6.3. Power conversion system	52
6.4. Handling of fuel subassemblies	52
6.4.1. In-vessel handling.....	52
6.4.2. Loading / unloading system.....	53
6.4.3. Ex-vessel handling	54
6.5. In-service instrumentation and inspection (ISIR)	54
6.5.1. Context and approach	54
6.5.2. In-service monitoring	55
6.5.3. Periodical inspection	56
6.6. Instrumentation and control	57
6.6.1. Context and approach	57
6.6.2. Basic principles for the design of Astrid's instrumentation and control system	58
6.6.3. Architecture elements for Astrid's instrumentation and control system	58
6.6.4. Possible technologies for the instrumentation and control system.....	58
6.6.5. Perspectives	58



7.

ASSOCIATED FACILITIES FOR THE CYCLE OF ASTRID	61
7.1. Associated fuel cycle - Adaptation to the specific features of fast breeder reactors	61
7.2. Evolution of technologies.....	62
7.3. Fuel cycle workshops	63
7.3.1. Core manufacturing facility (AFC)	63
7.3.2. Used fuel processing facility (ATC)	64
7.3.3. Facility for the manufacturing of elements containing minor actinides	65

8.

SIMULATION AND CALCULATION CODES - QUALIFICATION	67
8.1. Modelling tools according to the schedule of the project	67
8.2. Facilities of interest for the qualification of the core and the components of Astrid	68

9.

INDUSTRIAL ORGANISATION AND INTERNATIONAL COOPERATION OF THE ASTRID PROJECT	71
9.1. Industrial organisation of the project.....	71
9.1.1. Missions of the contracting authority	72
9.1.2. CEA internal organisation	73
9.2. International cooperation	73
9.2.1. In Europe	73
9.2.2. Outside Europe	74

10.

SCHEDULE AND COSTS	77
10.1. Schedule.....	77
10.2. Cost assessment	78

11.

CONCLUSION	81
11.1. Sodium-cooled fast reactors	81
11.2. Safety of SFRs.....	81
11.3. The Astrid technological demonstrator: objectives and specifications	82
11.4. R&D in the scope of the Astrid programme	83

A.

APPENDIX: SPECIFIC FEATURES IN THE DESIGN OF SODIUM-COOLED FAST REACTORS	87
---	-----------

.

REFERENCES	91
-------------------------	-----------

1.

INTRODUCTION

The sodium-cooled fast reactor (SFR) concept is one of the four fast neutron concepts selected by the Generation IV International Forum (GIF). In addition to France, the GIF partners for the SFR system are the USA, Japan, China, Russia, South Korea and Euratom.

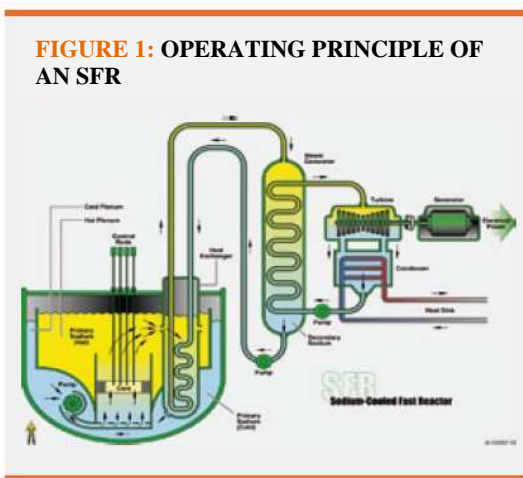

As we will see below, SFRs have favourable technical characteristics and they are the sole type of reactor for which significant industrial experience feedback is available. Approximately twenty prototypes or demonstrators have been built throughout the world and they total more than 400 reactor-years of operation, among which approximately 100 reactor-years for the four SFRs with significant power which have operated over a long period at industrial level (see Table No. 1). In France, the Phenix reactor was shut down in 2009, after more than 35 years of operation and it has become a very significant sum of knowledge.

The second chapter of this Tome 3 presents a summary of the lessons learned from the operation of SFRs at national and international levels and it highlights their advantages and drawbacks.

Based on this statement, in 2007, the French players (CEA, Areva and EDF) defined an R&D programme with a system-oriented vision whose purpose was to reinforce strong points and reduce weak points by means of significant technological innovations. This programme was oriented towards 4 priority progress areas:

- Design of a high-performance core with improved safety, in particular concerning prevention of severe accidents likely to cause complete core meltdown;

- Improved resistance to severe accidents and external aggressions, in particular design of redundant and diversified decay heat removal systems, as well as aspects related to the risk of recriticality and to molten core containment;
- Search for an optimised and safe power conversion system intended to reduce or even completely remove the risk of interaction between sodium and water;
- Reactor design options to make inspection and maintenance easier and, more generally, to improve the availability, the performance and the general economic characteristics of the facility.

The third chapter describes these priority research fields as well as the results obtained during the past 5 years.

The first purpose of the Astrid reactor (Astrid means “Advanced Sodium Technological Reactor for Industrial Demonstration”) is to demonstrate, at a sufficient scale, the abovementioned technological progress by qualifying the innovative options during its operation, in particular in the fields of safety and operability. Therefore, Astrid is a technological integration prototype which will make it possible to demonstrate the safety and the operation of 4th generation SFRs on an industrial scale. Astrid will also be used as a test bench for the use of advanced inspection and repair techniques. Its size must be sufficient to allow extrapolation to commercial reactors, however without being excessive, in order to limit the cost and the industrial risk.

Safety is at the heart of the Astrid project, mainly for the following reasons:

- The acceptability of nuclear energy in the future mainly relies on the demonstrated level of safety of facilities;
- The image of SFRs is much debated, in particular due to the perception of their safety. The specific features of SFRs (positive reactivity effect in case of sodium drainage, sodium risks, etc.) are often highlighted, however the suitable solutions are ignored and the intrinsic advantages are omitted (absence of pressure, significant thermal inertia, etc.);
- The Fukushima accident led everyone to reconsider the safety approaches and, through this, it has an impact on the design and operation of facilities.

Chapter 4 presents the specifications which the Astrid demonstrator will have to comply with and the associated safety objectives. Chapter 5 is dedicated to the resulting requirements and to the baseline choices applied to Astrid.

Chapter 6 describes, for all the components of Astrid, the design options already selected and the options for which the choice still remains open given the state of progress of the project. The main systems defined are as follows:

- the core;
- the nuclear island;
- the power conversion system;
- the fuel handling system;
- the instrumentation in the core and the inspectability and repairability of components essential to safety;
- the instrumentation and control system.

A fuel cycle needs to be associated with a fast neutron reactor, so that the whole nuclear system can be taken into consideration in order to assess its overall performance. The key facilities of the fuel cycle, such as the fuel manufacturing workshop and the irradiated fuel processing workshop necessary to demonstrate the plutonium multi-recycling, as well as the manufacturing line for minor actinide based elements to continue the demonstration of the technical feasibility of long-lived nuclear waste transmutation, are specifically described in Chapter 7. The main R&D facilities necessary for the qualification of the core and components of Astrid are also described.

Pursuant to the act dated 28 June 2006, CEA became the contracting authority of the Astrid project. CEA received a significant part of the funding for the basic design and the associated research, via the "Investment for the future» programme.

A specific organisation was implemented. The project was broken down into study batches entrusted to various industrial partners, preferentially within the scope of bilateral collaborations with the main players of the nuclear sector or through commercial contracts.

Chapter 8 describes this industrial organisation in detail and also describes the international cooperation in the field of the associated R&D.

In terms of scheduling, the work concerning the basic preliminary design of the Astrid project started in October 2010. It is composed of 2 phases:

- The first phase of the preliminary design, called AVP1, whose purpose is to analyse the open options, in particular the most innovative ones, in order to select the reference design at the end of 2012. This phase includes a preparation phase which made it possible to structure the project, formalise the expression of the needs and define the main milestones and deadlines; it ended in March 2011. During the AVP1 phase, the schedule of the project was analysed and a preliminary cost assessment action was initiated.

- The second phase of the preliminary design, called AVP2, will start in 2013. It will be aimed at confirming the design in order to have a complete and consistent basic preliminary design by late 2014. This basic preliminary design will be accompanied by a more thorough assessment of the cost and the schedule, and it will allow a decision to be made to continue the project.

At the beginning of the preliminary design, a certain number of design options were frozen. The options left open are subjected to an assessment and selection process so that they can be gradually frozen during the preliminary design.

The basic design is scheduled for between 2015 and 2017; it will be followed by the construction studies, the authorisation procedures and the construction itself. The design study phase itself therefore runs from 2010 to 2017, according to the initial schedule. At the same time, it will be necessary to carry out R&D actions and option selection validation actions; the results of these actions may have an impact on the contents and duration of the design studies.

Chapter 9 describes this forecast schedule until the construction phase and specifies the action proposed to assess the overall cost of the project.

In order to make the reading of the following chapters easier, a brief description of the specific features of SFRs is presented in Appendix 1.



2.

- EXPERIENCE FEEDBACK OF FAST REACTORS IN FRANCE AND WORLDWIDE 13**
- 2.1. Results of the operation of fast reactors worldwide.....13
- 2.2. Summary of experience feedback in various fields13
- 2.2.1. Experience acquired and intrinsic advantages.....13
- 2.2.2. Specific difficulties or problems14
- 2.2.2.1. Material selection.....14
- 2.2.2.2. Safety function related to control of the core reactivity.....15
- 2.2.2.3. Fuel handling15
- 2.2.2.4. Availability and control of the risks related to the sodium technology15
- 2.2.2.5. In-service inspection and repairability (ISIR)16
- 2.2.2.6. Dismantling16

2.

EXPERIENCE FEEDBACK OF FAST REACTORS IN FRANCE AND WORLDWIDE

The purpose of this chapter is to summarise the experience acquired with SFR systems in France and all over the world, analyse the incidents which occurred on this system and describe the most mature technological options as well as the fields in which progress is expected, in particular in terms of safety, performance, availability and cost.

2.1. RESULTS OF THE OPERATION OF FAST REACTORS WORLDWIDE

Since the commissioning of the first fast reactors in the 1950s, the fleet of fast reactors in the world is comprised of 13 reactors which operated over a time period ranging between 3 and 44 years and which are shut down today, and 6 operational reactors, among which 4 are actually in service (BOR-60, BN-600, FBTR, CEFR) and 2 which are being repaired (Monju and Joyo). Furthermore, 2 reactors are being built (BN-800 in Russia and PFBR in India). As a result, the SFR

system has totalled today 404 years of operation associated with all of these reactors (see Table No. 1).

It is to be noted that although Europe and the USA have dominated the development of this system as from the beginning, Asian countries now have a leading position.

2.2. SUMMARY OF EXPERIENCE FEEDBACK IN VARIOUS FIELDS

2.2.1. EXPERIENCE ACQUIRED AND INTRINSIC ADVANTAGES

Therefore, significant experience feedback exists today for the SFR system, both in terms of design, manufacturing, commissioning, operation and functioning over time. In particular in France, the expertise acquired over the 36 years of

TABLE 1: WORLD FLEET OF SFRs AND TOTAL OPERATING DURATION - SITUATION IN 2012

Reactor (Country)	Thermal power (MW)	Start	Shutdown	Operating duration (years)
EBR-I (USA)	1.4	1951	1963	12
BR-5/BR-10 (Russia)	8	1958	2002	44
DFR (England)	60	1959	1977	18
EBR-II (USA)	62.5	1961	1994	33
FERMI 1 (USA)	200	1963	1972	9
RAPSODIE (France)	40	1967	1983	16
SEFOR (USA)	20	1969	1972	3
BN-350 (Kazakhstan)	750	1972	1999	27
PHENIX (France)	563	1973	2009	36
PFR (England)	650	1974	1994	20
KNK-II (Germany)	58	1977	1991	14
FFTF (USA)	400	1980	1993	13
SUPERPHENIX (France)	3,000	1985	1997	12
JOYO (Japan)	50-75/100/140	1977		32
MONJU (Japan)	714	1994		15
BOR-60 (Russia)	55	1968		43
BN-600 (Russia)	1,470	1980		31
FBTR (India)	40	1985		25
CEFR (China)	65	2010		1
BN-800 (Russia)	2,100	Under construction		
PFBR (India)	1,250	Under construction		
Total				404

2.

EXPERIENCE FEEDBACK OF FAST REACTORS IN FRANCE AND WORLDWIDE

operation of Phenix, the experience added by the design and construction of Superphenix as well as the studies associated with the EFR (European Fast Reactor) project are very rich and taken into account as from the design phase of the Astrid technological demonstrator.

Preservation of this knowledge and reappropriation of industrial control and R&D capabilities are also objectives of the Astrid programme.

The detailed technical analysis of this experience feedback forms the subject of specific documents. A very brief summary will highlight the achievements and intrinsic advantages of the SFR system:

- The operation of SFRs has demonstrated the excellent use of the uranium resource as well as the capability of these reactors to recycle the plutonium without any limitation in the number of recycling operations (multi-recycling). Unlike the vast majority of reactors currently operated or under construction all over the world, which consume less than 1% of natural uranium to extract the energy contained in it, SFRs have the capability to consume, in theory, almost the whole resource via multi-recycling of the successive used fuels. In the case of Phenix, 520 used fuel subassemblies were reprocessed in three different facilities, which means a little more than 26 metric tonnes of fuels. As a result, 4.4 metric tonnes of plutonium were extracted. The breeding ratio⁴ was confirmed and measured at 1.16. Then 3.3 metric tonnes of this plutonium were used to manufacture new subassemblies for Phenix and these subassemblies were used in reactors, in a multi-recycling strategy.
- The pool concept appears to be preferable to loop concept, since this pool type architecture allows in particular a very good start of the natural circulation of the coolant and, in practice, it eliminates the risk of the core being no longer immersed or the risk of loss of decay heat removal systems.
- The primary system is not pressurised but it has a very high thermal inertia which provides operators with significant time to intervene in case of loss of cooling.
- In operation, there is a high margin with the sodium boiling temperature, typically 300°C.
- The oxide fuel is more mature when compared with the limited experience feedback concerning dense fuels (carbide, nitride and metal). In terms of performance, world records were achieved, in Phenix, by experimental subassemblies (Boitix 9 which totalled 144 GWd/t in burn-up fraction). This performance was achieved while keeping the number of clad failures to a very low level. Among approximately 150,000 fuel pins irradiated in Phenix during its 36 years of operation, only 15 clad failures occurred (none in Superphenix), half of which occurred on experimental fuel pins irradiated beyond the “standard” characteristics.

- The control of the reactor appears to be easy, thanks to the absence of burnable poisons (to compensate for the excess reactivity) contrary to PWRs, thanks to the absence of poisoning effect generated by highly-neutron-absorbing fission products such as xenon or samarium in PWRs, and thanks to self-stabilising thermal feedback.
- Active or passive decay heat removal systems, based on two types of cold sources (air and water) have demonstrated their efficiency. For the 4th generation reactors, higher diversification of these systems will be aimed at in order to further improve the safety of these facilities.
- The environmental assessment is very positive and the collective dose received by workers is very low when compared with other types of reactors (in Phenix, over the 36 years of operation, the average annual dose received by each person is 0.05 mSv, to be compared with natural irradiation – except medical and human activities – which is 2.5 mSv/year).

However, this experience feedback also highlights difficulties or problems specific to SFRs.

2.2.2. SPECIFIC DIFFICULTIES OR PROBLEMS

2.2.2.1. MATERIAL SELECTION

Several material selections proved to be unsuitable. For example, let us mention the crack and leakage of the ex-vessel fuel storage tank⁵⁵ of Superphenix in March 1987 due to the use of steel 15D3 (ferritic molybdenum steel). This steel had been selected for its high temperature performance but there was no sufficiently long experience available as regards its use in vessels containing liquid sodium.

Similarly, steel 321 was extensively used in Phenix and PFR and, after some time, it exhibited cracks due to the residual welding stresses, in particular in the hot and thick areas. Among other things, this phenomenon led to gradual replacement of almost all the parts made of steel 321 in Phenix, multiple and successive repairs on the PFR steam generators and to the implementation of surveillance of all parts made of steel 321 in the existing reactors.

This experience feedback also makes it possible to know which materials had a correct behaviour over time, and it is a fundamental asset to design the various systems and components of future SFRs. This experience feedback will be completed in the years to come thanks to the dismantling of the currently shut down SFRs throughout the world, among which Phenix and Superphenix, and thanks to the sampling of irradiated materials (components, structure elements, cladding materials, fuels, etc.) whose analysis will considerably improve the databases. The Phenix reactor contains some materials which achieved records in terms of integrated dose and, as such, it is a real “treasure” which has to be used.

⁴ – The breeding ratio is defined as the ratio of the number of produced fissile nuclei to the number of destroyed fissile nuclei per unit of time.

⁵⁵ – Component in which used fuels are temporarily stored in sodium to allow them to cool down.

2.2.2.2. SAFETY FUNCTION RELATED TO CONTROL OF THE CORE REACTIVITY

In 1989 and 1990, four emergency reactor shutdowns occurred in Phenix due to the sudden drop in the core reactivity (negative reactivity trips). Even if the exact root cause of these incidents still remains to be ascertained, the investigations performed showed that fast reactors are sensitive to overall core movements. Therefore, particular care must be given to this specific feature. In order to limit the risks of core compaction, options must be implemented during the design of the subassemblies, such as bosses, called “contact pads”, to be installed on the hexagonal tubes of each subassembly so as to prevent any unwanted closing in of the tubes.

More generally, it will be necessary to strive for and achieve a natural behaviour of fast reactor cores in order to make them more resistant to any disturbance and prevent any possibility of runaway of the chain reaction.

2.2.2.3. FUEL HANDLING

Handling of the fuel subassemblies in an SFR is significantly different from handling in water reactors. First of all, the opacity of sodium requires to work “blind” as long as the fuel subassemblies are inside the reactor or in the sodium storage tank. Systems to check for movements and obstacles (ultrasonic “viewing” in particular) have been developed to remedy this drawback. Then, the subassemblies need to be cleaned from the sodium which may remain attached to them before they can be stored in water. These operations require radiological protection and they are performed using remote-controlled equipment. The experience feedback showed a gradual extension of the durations of the core renewal campaigns, due on the one hand to equipment ageing (more frequent failures) and on the other hand to stricter assembly movement control procedures requiring a greater number of checks and hold points during the operations. Additional R&D is necessary to improve the handling and cleaning speeds in order to preserve optimum reactor availability.

2.2.2.4. AVAILABILITY AND CONTROL OF THE RISKS RELATED TO THE SODIUM TECHNOLOGY

The experience feedback shows that the incidents related to the use of sodium mainly had consequences in terms of availability of the facilities (apart from the media or political context, as in the case of Superphenix or Monju, as this context sometimes significantly extended the shutdown durations). The most striking examples are given below:

- in Superphenix, pollution by air of the primary sodium (8 months of unavailability due to a faulty neoprene membrane compressor) and argon leakage at an intermediate exchanger (7 months of unavailability due to a crack on a 22 mm diameter tube), leakage at the storage tank (10 months of shutdown);
- oil ingress in the PFR primary system (18 months of shutdown);
- sodium leakage in Monju in 1995, leading to shutdown of the facility until 2010;

- fuel handling incidents in FBTR and in Joyo (two years of unavailability in the first case, probably even more in the second case). It is to be noted that these two reactors are not equipped with ultrasonic viewing systems like Phenix, which could have made it possible to avoid these incidents.

We also have to mention the sodium leakages (one per year and per operating reactor in average, however it is to be noted that the last leakage occurred in BN-600 in May 1994), usually involving small quantities (approximately one kilogramme), rapidly detected and not generating significant fires, and leakages at steam generator tubes leading to small sodium-water reactions (five leakages in Phenix, approximately twelve in BN-600, approximately forty in PFR) or to a large sodium-washer reactions (BN-350 in October 1973 and February 1975, PFR in February 1987).

The analysis of the sodium-related incidents led to the conclusion that most of these incidents had no consequences on the safety of the reactors, even if some of these incidents revealed weak points in the former safety demonstration. In another context, the fire which occurred in the solar power plant of Almeria (Spain) led to a review of the basic assumptions related to the nature of sodium fires, thus improving the industrial experience feedback related to the use of sodium.

All in all, the number of events is rather small, in particular for reactors which are prototypes. For this reason, it is normal that the starting phase of a reactor which is the first one of a series requires a period for adjustment and validation of the technological options. The integration, during the design phase of future reactors, of the huge knowledge available thanks to the experience feedback of the operation of former projects allows us to expect availability rates close to those of existing Light Water Reactors (LWR). Therefore, for example, let us mention that the BN-600 reactor, which used the experience feedback accumulated in Russia thanks to the operation of prototype reactors and the operation of BN-350, reaches availability rates comparable (and in some cases higher) to those of the Russian water reactors. These availability rates are similar to those of the French Pressurised Water Reactors (PWR) which were started at the same period (1980), such as the Tricastin 1 reactor; as a matter of fact, BN-600 has a load factor⁶⁶ of almost 75% over the period between 1982 and 2008.

The shutdown periods appear to be very significant with regard to the number of events. Beyond the time necessary to analyse, investigate and repair the incident itself, the actions which generate extended shutdown periods are mainly the verifications of conformity of the components or structures requested by the nuclear safety authorities. This statement proves that it is necessary to implement high-performance in-service inspection and repairability; this remains a challenge, given the fact that sodium is opaque and reactive.

⁶⁶ – Here, the load factor, or capacity factor, is the ratio of the gross electricity production to the gross nominal electrical power of the facility multiplied by the operating duration considered.

2.

EXPERIENCE FEEDBACK OF FAST REACTORS IN FRANCE AND WORLDWIDE

2.2.2.5. IN-SERVICE INSPECTION AND REPAIRABILITY (ISIR)

Significant experience feedback has been accumulated with the Phenix reactor in terms of maintenance and inspection, in particular during the programme aimed at extending the service life of Phenix. Several significant actions were carried out on the reactor and its main systems. The replacement and repair of the intermediate exchangers, primary pumps and steam generator modules, which had been planned as from the design of the reactor, were carried out many times and successfully. Significant portions of the intermediate systems were repaired, with the replacement of the base metal when it turned out that steel 321 was not suitable for the operating conditions of the hottest parts. On that occasion, an original and efficient procedure was developed to weld the new portions onto the original pipes. A Closed Circuit TeleVision (CCTV) inspection was carried out on the upper internal structures of the reactor block, in particular the above core structure and the network of fuel subassembly heads, using optical devices inserted into the primary system after drainage of half of the sodium (400 metric tonnes) under radiation of approximately 100 Grays per hour. This inspection revealed that these structures were in excellent condition after thirty years of operation. The ultrasonic test performed on the conical skirt which supports the diagrid and the core inside the main vessel demonstrated that there were no defects in this structure which is fundamental for the safety of the reactor, in particular in case of earthquake. This inspection was performed using the skirt itself as a wave guide, from the outside of the main vessel and over a distance of more than three meters at the heart of the primary sodium maintained at 155°C. This operation can be qualified as “world first”.

2.2.2.6. DISMANTLING

The Superphenix reactor and several experimental SFRs are being dismantled. The main lessons which can be learned, in particular for the design of future SFRs, from the studies and operations related to the dismantling of these reactors are the following:

- complete core unloading is a long operation which sometimes requires processes or equipment items which were not provided for in the operation phase;
- complete drainage of the sodium from the reactor is also a long operation which requires complex work; it is to be noted that, until now, what happens to the sodium is different from one facility to the other (direct or indirect reuse, release of sodium salt into the river or marine environment, incorporation into concrete);
- possible presence of sodium in the form of aerosol deposits, for instance in the penetrations of the above core structures of reactors, needs to be taken into account during the reactor water filling when this process is selected to provide a biological protection during the dismantling operations;
- cold traps (or similar equipment) in which sodium compounds (oxides, hydrides, etc.) and radioactive elements (activation products, fission products in case of leaking fuel

clads, etc.) concentrate during the service life of the reactor, are equipment which generate the highest level of chemical and radiological risks during dismantling;

- processing of the sodium-potassium alloy (NaK) involves chemical risks which require perfect control of a complex process;
- the radiological source term is concentrated in a few structures located close to the core, in particular in case of presence of some materials such as stellites which become highly activated under a neutron flux (on the contrary, the overall activity of nuclear waste produced by an SFR is lower than the activity of the waste of the other types of reactors, and a significant part of the waste produced during the dismantling operations can be disposed of through the conventional channels);
- special care must be given to the tritium release limits during the dismantling of components which were in contact with the primary sodium.

Generally speaking, the deconstruction of SFRs does not involve any technical dead end or major difficulty and it is very similar to the dismantling of the other types of nuclear reactors or facilities.



PRIORITY IMPROVEMENT AREAS AND ASSOCIATED R&D PROGRESS 19

- 3.1. Reactor safety 19
 - 3.1.1. Prevention of severe accidents 19
 - 3.1.1.1. High-performance, improved safety core 19
 - 3.1.1.2. Reactor shutdown systems 22
 - 3.1.1.3. Decay heat removal system 22
 - 3.1.1.4. Keeping the sodium inventory in the primary circuit 23
 - 3.1.2. Mitigation of severe accidents 23
 - 3.1.3. Sodium-water risk: power conversion system 25
 - 3.1.3.1. Brayton cycle power conversion system 25
 - 3.1.3.2. Water-steam Rankine cycle power conversion system 27
 - 3.1.4. Sodium leak detection 28
- 3.2. Higher availability than former SFRs and reduced shutdown times 28
 - 3.2.1. Instrumentation and inspection, monitoring and repairability 28
 - 3.2.2. Fuel subassembly handling and cleaning 29

3.

PRIORITY IMPROVEMENT AREAS AND ASSOCIATED R&D PROGRESS

The analysis of the experience feedback of SFRs highlighted the difficult points which still remain to be solved before an industrial product that complies with the objectives of the 4th generation can be available. Solving these problems involves technological innovations which go far beyond an incremental approach in comparison to Superphenix and the EFR project.

The table below details the R&D areas and the technological orientations selected for research on improvements and innovations.

The progress of the work related to these major priority innovation objectives is presented below.

3.1. REACTOR SAFETY

3.1.1. PREVENTION OF SEVERE ACCIDENTS

3.1.1.1. HIGH-PERFORMANCE, IMPROVED SAFETY CORE

In terms of safety objectives, the 4th generation SFRs are required to achieve a better safety level than before, and this safety level shall be at least equivalent to that of the nuclear reactors which will be commissioned at the same time. The safety objectives for the reactors under construction are formalised in the WENRA⁷ document “Safety Objectives for New Nuclear Power Plants”.

To comply with these objectives, the prevention of the risk of complete core meltdown must be given special care. The reactor protection and malfunction detection systems must therefore achieve a very high level of reliability and redundancy, and this must be demonstrated through a deterministic and probabilistic approach. An additional approach consists of implementing a natural behaviour of the core which will make severe accident prevention and mitigation easy. The robustness of the safety demonstration shall be ensured by means of a combined probabilistic and deterministic approach.

⁷ – Western European Nuclear Regulators’ Association.

TABLE 2: PRIORITY R&D AREAS FOR SFRs

FORMER EXPERIENCE FEEDBACK	R&D areas / Technical innovations
Reactivity of cores Void coefficient problem → Safety	<ul style="list-style-type: none"> ■ Optimisation of the cores to improve the natural behaviour in case of abnormal transient. Investigation into heterogeneous cores.
Sodium-water reaction → Safety – Availability	<ul style="list-style-type: none"> ■ Modular steam generators ■ Reverse steam generators (sodium in the tubes) ■ Gas power conversion system instead of water-steam power conversion system
Sodium-air reaction → Safety	<ul style="list-style-type: none"> ■ Innovation for sodium leakage detection ■ Studies related to sodium aerosols
Severe accidents → Safety	<ul style="list-style-type: none"> ■ Path of the corium ■ Core catcher ■ Interaction between corium and sodium
Decay heat removal → Safety	<ul style="list-style-type: none"> ■ Combination of well-proven systems, diversification of the cold source ■ Decay heat evacuation through the vessel
ISIR → Safety – Availability	<ul style="list-style-type: none"> ■ Simplified nuclear island design ■ New techniques: acoustic detection, laser measurements ■ High temperature ultrasonic sensors ■ High temperature fission chamber ■ Optical fibres ■ Instrumentation for sodium flowrate measurement for assemblies ■ Carrying robots for inspection or repair ■ Under sodium viewing



**PRIORITY IMPROVEMENT AREAS
AND ASSOCIATED R&D
PROGRESS**

The design studies concerning the natural behaviour of the core are focused on an analysis of accident situations belonging to two main categories: the reactivity insertion accidents and the core cooling failure accidents.

1. Reactivity insertion accidents

There are three possible types of reactivity insertion:

- Through drainage of the sodium from the core, for large size conventional cores exhibiting positive associated reactivity coefficients⁸. The associated accident sequences are a gas bubble going through the core, or the sodium which boils during a loss of coolant accident in the core;
- Through unexpected withdrawal of one or several control rods. These rods are inserted into the core at the beginning of the cycle to compensate for the initial reactivity reserve necessary to withstand the duration of the cycle. If it is not detected early, an unexpected withdrawal can cause the degradation of the fuel in certain subassemblies due to the local increase of power;
- Through a core compaction movement. Due to the clearances between the subassemblies, the core is not, in nominal operation, in its most reactive geometrical configuration. Therefore, core compaction, by filling all or part of the clearances between the subassemblies, can possibly lead to reactivity insertion.

⁸ – Sodium can slow down neutrons. Disappearance of sodium leads to the following:

- Positive reactivity effect due to “hardening” of the neutron spectrum; as the neutrons are less efficiently slowed down;
- Negative reactivity effect due to the increase of neutron leakage out of the core;
- As neutron leakages are smaller in large size cores, the most positive drainage reactivity effects are obtained for high power, large size cores.

2. Core cooling failure accidents of different natures

- Overall accident which affects the entire core; typically, the primary and secondary sodium flows are stopped following the loss of the electrical power sources which supply the pumps, this being likely to lead to core damage further to the appearance of sodium boiling;
- Local accident, which can affect one or several subassemblies following a fast loss of coolant such as a failure of the connection between the pump and the diagrid (Liposo) or following a blocked subassembly leading to local fuel meltdown, likely to entail a feared scenario of propagation of the fusion phenomenon up to a complete core meltdown.

The R&D work is based on the development of a core design methodology, in particular the Cocons approach (design of naturally safe cores). This gradual improvement methodology relies on an analysis of the core reactivity coefficients which play an important part in the behaviour of the reactor, then on their optimisation so as to make the core more resistant to damage in the abovementioned accident situations. Then, multicriteria optimisation methods have been developed to take the complexity and variety of accident sequences into account.

These studies revealed the need to first reduce the reactivity effect due to the loss of sodium of the core.

Based on these orientations, the R&D teams defined an innovative core concept, covered by a common CEA-EDF-Areva patent and called CFV (core with low reactivity effect in case of sodium drainage); this concept features major improvements in comparison to conventional concepts. The main characteristic of this concept is that it has a very low or even negative reactivity effect in case of complete drainage of the sodium, including for a high power reactor.

This performance is made possible by:

- the reduction of the proportion of sodium inside the core through a reduction of the diameter of the wire used for separation between the fuel pins,

FIGURE 3: SCHEMATIC DIAGRAM OF THE FUEL PIN AND CFV CORE

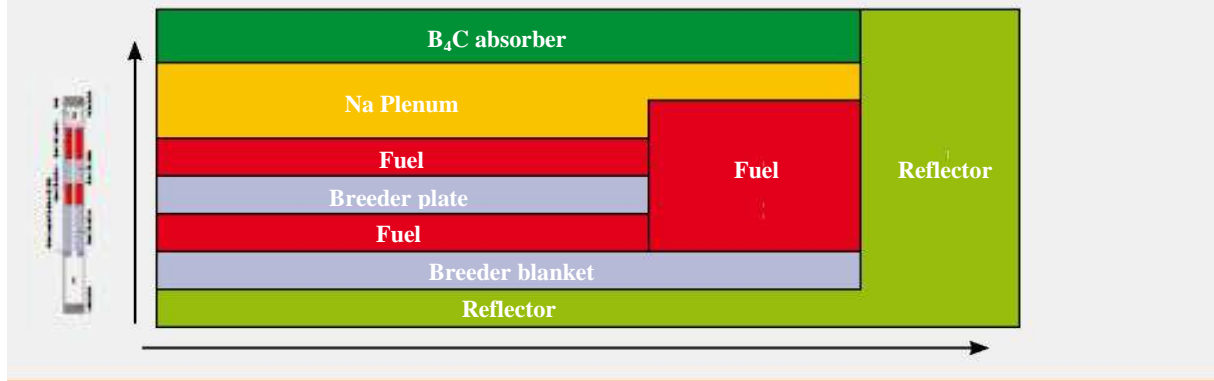

- the application of the “sodium plenum” concept which is materialised by a cavity normally filled with sodium, located above the fuel pin bundle inside the fuel subassemblies. In the event of drained situation following partial loss of sodium in the core, this plenum will allow neutron leakage out of the core. The innovation of the CFV core lies in the combination of this sodium plenum concept with the core heterogeneous geometry concept (presence of a fertile plate located approximately at mid-height in the core) and with the “crucible” core configuration (differentiation between the heights of the internal and external fissile zones). An absorber plate is also installed above the sodium plenum. This combination increases the leakage effect of the neutrons of the plenum (increase by a factor of 3 with respect to a configuration with just the sodium plenum) and therefore, it compensates for the positive reactivity insertion due to the drainage of the fuel zone only. As a result, the reactivity effect related to complete sodium drainage becomes negative. It is also worth noting that all these feedback effects start before the sodium begins to boil, as from the time its expansion begins under the effect of heating.

The fuel pin and the RZ geometry description of the CFV core are presented on Figure 3.1.

These characteristics allow us to consider a more favourable behaviour of the CFV core during unprotected complete loss of cooling accidents (total failure of the electrical power sources). Furthermore, the small loss of reactivity during the cycle, which also characterises the CFV core, is favourable in case of unexpected control rod withdrawal.

The other accident sequences (fast blockage of fuel subassemblies, core compaction, drainage due to gas passage) can be precluded, in practice, through the use of early detection technological options (innovative instrumentation) or physical limitation options (reinforced plates to limit core compaction, removal of gas release sources).

To master the specificity of the CFV core based on the combination of options and separated multiple effects, and to certify the calculation uncertainties associated with the main neutron parameters, an experimental physics programme (called “Genesis”) was defined. A part of this programme is dedicated to analytical assessments and it is scheduled to be carried out in the BFS critical mock-up in Russia, while the tests to validate the impact of the combination of these effects will be performed from 2017 in the Masurca critical mock-up (under renovation) installed on the CEA centre of Cadarache (France). Given the innovative aspect of this core, other tests or development work will certainly be necessary and they will be defined as the studies and the R&D progress. For example, the severe accident simulation codes will require further adaptation or development.

The CFV core concept requires a specific material R&D programme:

- the reduction of the spacing wire leads to a tight network of fuel pins. Therefore, it becomes absolutely necessary that the cladding materials exhibit low swelling in the operating conditions of an SFR, in order to achieve the burn-up

fraction objectives defined for the commercial reactors. The current reference cladding material is a work-hardened 1515 Ti austenitic steel, material grade AIM1, that is to say the last material grade used in the Phenix reactor; this material has a satisfactory behaviour but its use is limited to approximately 100 dpa (displacements per atom). An R&D programme is in progress to develop a material grade called AIM2, which will be compatible with an objective of 120 dpa. For the commercial power plants, the development of an oxide dispersion strengthened ferritic-martensitic steel (ODS steel) is under study. More advanced silicon-carbide-based materials (SiCSiC) and, to a smaller extent, vanadium, are also considered as they provide additional margins in terms of heat resistance. R&D work is in progress to determine the feasibility of these materials.

- a programme to characterise the behaviour of the core materials at high temperatures (in particular the material of the hexagonal tubes, made of steel EM10), to substantiate the preservation of the geometry of the core for transients such as loss of cooling.

This development and qualification programme relies, among others, on the use of irradiations carried out in Phenix and on an examination programme (non-destructive testing and destructive testing) in the various CEA laboratories. In particular, subassemblies with heterogeneous geometry, called PAVIX, made of an AIM1 cladding material and EM10 hexagonal tubes, were irradiated during the last operating cycles of Phenix; they should bring a very useful quantity of data for the qualification of the fuels for CFV type cores.

In the long run, within the scope of a gradual improvement action, it appears that the use of a denser and colder fuel than the reference oxide fuel will bring interesting perspectives. The best compromise is given by nitride or carbide type dense ceramics. As a matter of fact, these ceramics have the best margins in terms of meltdown, thanks to a good thermal conductivity and a high melting temperature. Their rather low core temperatures make these ceramics more suitable for loss of coolant accidents. The nitride type ceramic has similar characteristics to those of the carbide type, but its problems of dissociation at rather low temperature make it less suitable in comparison to carbide type ceramic.

As regards the carbide fuel, the experience feedback of India, which has developed this type of fuel, highlights the difficulties to manufacture this fuel on a large scale (risk related to the pyrophoric characteristic of carbide).

Foreign countries (USA, South Korea, India) carry on the study and development of metal fuels, mainly with a view to improve the breeding potential. Such fuels have advantages (high density, good conductivity, lower interactions with sodium) but they also have significant drawbacks (lower melting temperature, higher effect with sodium void reactivity, etc.).

To conclude, in addition to continuing the development of oxide fuels and monitoring the studies carried out abroad (nitride, metal), it appears interesting to continue our efforts on the long run to explore the potentialities of carbide fuel cores which will allow us to go even further in terms of favourable natural behaviour.

3.1.1.2. REACTOR SHUTDOWN SYSTEMS

For an SFR, the reactor shutdown function is usually performed by two families of rods (control and shutdown rods); these rods are diversified and redundant as no system exists based on a soluble poison, such as the injection of boron in a PWR. Diversification therefore relies on a different design and construction of the control rod mechanisms, a protection system also diversified from the physical data and sensors to the actuators and a combination of both types of rod mechanisms and both types of protection systems in order to provide the automatic shutdown function with a high level of reliability.

In order to further improve the reliability of the shutdown function and achieve an almost total practical elimination of the risks of unprotected accidents, a third intrinsic shutdown level is searched for, based on a completely different operating principle than that of the other two systems. This approach is covered by an R&D programme with specifications and requirements suitable for the objectives allocated to the 4th generation reactors.

Such a very innovative concept of third shutdown level, called Sepia (SEntinelle for Passive Insertion of Antireactivity) was designed and a patent was filed. This third shutdown level can be integrated into a fuel subassembly independent from the rods and, as a consequence, it is not susceptible to the possible causes which could make the other conventional shutdown systems inoperative; its operation is activated passively by the increasing temperature of the sodium which flows in the subassembly, in case of a threshold value being exceeded.



Figure 3.2 illustrates an example of Sepia based on a differential thermal expansion device, but other activating systems are under study (“thermal fuse” for example).

Such a system improves the capability to stop the nuclear power in all circumstances, this being a first order requirement. But beyond this, it is also absolutely necessary to ensure continuous evacuation of the residual heat, and the Fukushima accident highlighted this point.

3.1.1.3. DECAY HEAT REMOVAL SYSTEM

For the future SFRs, the main R&D objective consists of reinforcing the design solutions to achieve a robust demonstration of the practical elimination of the total loss of decay heat removal (DHR) systems over a long period. The architectures have been redefined since 2007, which made it possible to identify priority work areas:

- better use of the intrinsic characteristics of the sodium (thermal inertia, boiling margin, etc.) to develop designs which will improve the initiation and holding of natural circulation. This relies on cores with reduced pressure loss and on the optimisation of the components in the main vessel. The accurate assessment of the way to achieve this performance (this capability has already been demonstrated by real tests on the Phenix and Superphenix reactors) relies on the progress of simulation and on the contribution of intensive calculations, for example by means of the possibility to perform three-dimensional calculations coupled with system calculations for the intermediate exchangers (see Figure 3.3). For example, in order to take advantage of this capability to operate in natural convection in the primary system, with a hydraulic system going through the intermediate exchanger, design feasibility studies were performed for a DHR exchanger integrated into an intermediate exchanger.
- Development of probabilistic safety assessment models adapted to the specificities of SFRs, in order to assess the robustness of the architectures with respect to the objectives and the advantage of the diversification of the cold sources; these models will finally contribute to the demonstration of the achievement of these objectives.
- Search for innovation in the design of DHR systems making it possible to reduce the risks related to the identified common modes such as, for example:
 - all the exchangers immersed in the main vessel can be subjected to similar loading,
 - most of the sodium systems go through the reactor slab and they are potentially vulnerable to common loads (sodium fire for example).

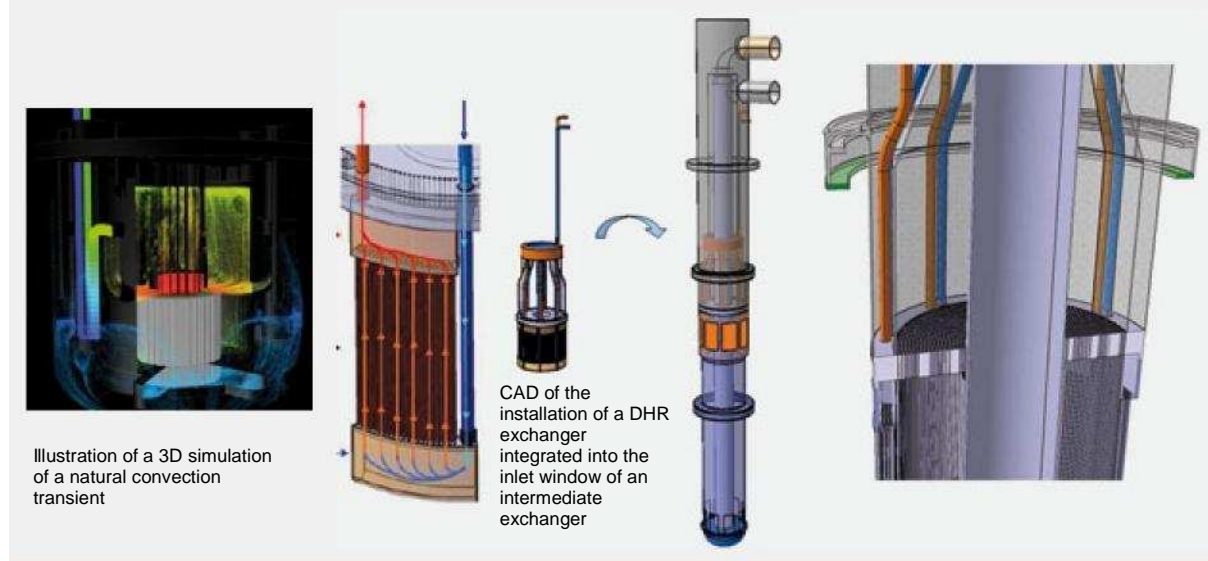
FIGURE 3.3: SIMULATION TO DESIGN A DECAY HEAT REMOVAL SYSTEM

Therefore, actions are in progress to develop additional systems which will make residual heat extraction by the external structures easier, by attempting to rely on a better comprehension of the evolution of the emissivity of the vessel materials and on the development of exchangers in the inter-vessel space or in the reactor pit. We are also studying the potential synergy of these new systems with the requirements on the post-accident decay heat removal systems in case of selection of a core catcher located outside the main vessel. And finally, should these solutions prove to have insufficient efficiency, other engineering approaches are under study (protection and sectoring of the exchangers on the slab, etc.).

The objective of the implementation of these solutions in Astrid, as we will see in Chapter 6, is to practically eliminate the risk of complete and prolonged loss of the decay heat removal function.

3.1.1.4. KEEPING THE SODIUM INVENTORY IN THE PRIMARY CIRCUIT

The accident which occurred in the Japanese power plant of Fukushima-Daïchi demonstrated how much it is important to guarantee the inventory in primary fluid in case of severe accident. On a pool type SFR, the approach consists in ensuring a very high prevention level with a safety vessel which will recover the sodium in case of leakage from the main vessel, so that the core remains immersed and can be cooled. This approach has been completed with a procedure intended to guarantee the safety of the reactor should the safety vessel have a leak as well. For the future SFRs, this approach is integrated as from the design phase.

3.1.2. MITIGATION OF SEVERE ACCIDENTS

Within the scope of defence in depth, irrespective of the performance level reached in terms of prevention, and in consistency with the approaches followed for the 3rd generation reactors, it is absolutely necessary to take the possibility of a core meltdown into account as from the reactor design phase.

All the steps and devices implemented to limit the consequences of a complete core meltdown are referred to as “mitigation”. For the 4th generation reactors, the purpose of mitigation is to demonstrate that massive release of radioactivity into the environment is not possible and that only counter-measures limited in space and time may possibly be necessary for the public.

In case of degradation of the core, the objective of the studies carried out is first to analyse the various accident scenarios and assess the potential risks in terms of release of mechanical energy and source term. Then, it is proper to propose and validate a set of mitigation means making it possible to preclude early or significant release of radioactivity into the environment so that, even in case of a severe accident, the implementation (as applicable) of measures to protect the population will be limited in time and space.

This objective is taken into account and integrated as from the core design phase through the application of design provisions which will prevent the situation from getting worse. In this context, the reduction of the reactivity coefficient in case of drainage of the scheduled cores (CFV core) appears to be a good thing in the first phase of an accident, by limiting the potential mechanical energy and, therefore, the risk of degradation of the primary containment. In order to manage the molten core, it is necessary to keep any possible recriticality under control, through two main areas of study:

FIGURE 3.4: SEVERE ACCIDENTS AND ASSOCIATED MODELLING TOOLS

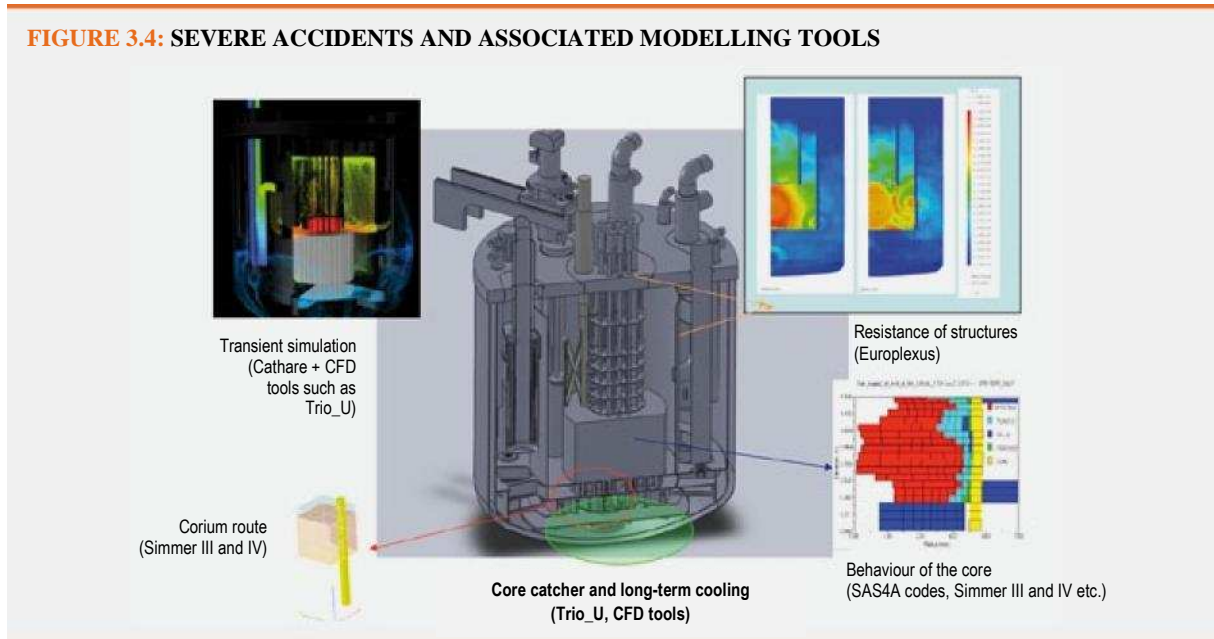

- Possibility to insert antireactivity in the molten fuel (through dilution of the fuel or through the addition of neutron absorbers); concerning the CFV core, the upper neutron shielding (PNS) contains absorbers, and the assessment of its contribution in such degraded situations is in progress.
- Possibility to disperse the molten fuel out of the core area; the Japanese JSFR concept proposed by JAEA is based on two devices:
 - a device named Faidus to eject a sufficient quantity of molten fuel out of the core in order to maintain a subcritical state during the period necessary to insert additional absorbers. It is to be noted that, in the end, the ejected fuel will return to the molten core area;
 - a CRGT device (Control Rod Guide Tube) to eject the corium below the core. The adaptation of the CRGT concept is under study for a CFV type concept in a reactor with pool architecture.

These studies to assess the behaviour of the core and the primary containment rely on a constant strive to develop the computation chain used to assess the consequences of a degradation of the core, to adapt this computation chain to the design options studied and to their validation (see Figure 3.4). To support this validation, CEA has access to the results of the EAGLE programme carried out by JAEA for the validation of the CRGT concept, and it is studying the feasibility of an additional experimental programme to validate the simulation tools for the case of the calculations of geometry of a core with a tightened pin bundle (CFV type).

Finally, concerning the mitigation means, it is scheduled to install a core catcher able to contain the entire corium inventory. The main functional requirements for the core catcher are as follows:

- Geographical containment of the corium without aggression of the containment barriers, in order to limit the consequences out of the site;

- Keeping the corium in a subcritical state to prevent any recriticality accident;
- Long-term cooling of the corium to guarantee that the containment will be maintained and to prevent the corium pressure from rising;
- Preservation of the long-term mechanical strength of the core catcher and the associated structures;
- Instrumentation systems to transmit the information concerning the characteristics of the corium in post-accident situations.

Finally, the design of a core catcher is dependent on the options selected for the decay heat removal system and for the containment and it is also dependent on the comprehension of the possible routes of the corium.

A multicriteria analysis of the various severe accident scenarios and of the possible corium route was initiated in order to study the suitability of three different types of core catchers, both in terms of design feasibility and robustness of the demonstration as regards the safety objectives and the previous functional requirements:

- An internal core catcher, located in the main vessel, which will maintain the integrity of the main vessel but will require to guarantee that the possible routes of the corium remain under control and that the performance of such a component in the primary system is maintained over time;
- An inter-vessel core catcher, located at the bottom of the space between the main vessel and the safety vessel, to guarantee the integrity of the safety vessel; such a core catcher would avoid the constraints related to the preservation of performance of a component in the primary system, but it transfers the design constraints into a reduced space potentially in contradiction with the inspectability requirements (see Figure 3.5);

FIGURE 3.5: EXAMPLE OF AN INTER-VESSEL CORE CATCHER

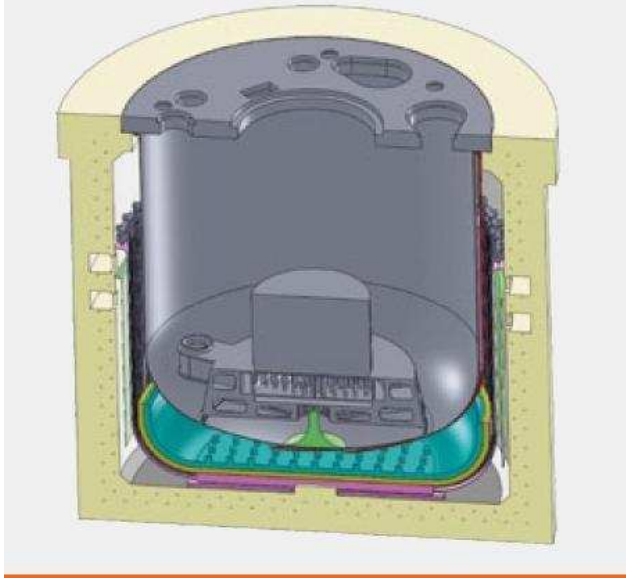

- An external core catcher, located at the bottom of the reactor pit; this type of core catcher transfers the design constraints to the layout of the reactor pit, in particular for the long-term decay heat removal system, and also on the sealing with the reactor building.

Given the requirement to maintain the corium in a subcritical state in the long term, and given the phenomena of interaction between the corium and the core catcher, a possibility is being studied in order to add a layer of sacrificial materials (to prevent the risk of material abrasion) associated with a neutron absorber. An R&D programme is in progress to assess the performance of these materials as well as their resistance over time, and this programme will contribute to the selection of options for the core catcher.

3.1.3. SODIUM-WATER RISK: POWER CONVERSION SYSTEM

Two different approaches were studied to design innovative power conversion systems:

- A completely new approach which removes the use of water and which uses a Brayton cycle gas power conversion system. Therefore, this approach gives a simple and final response to the reactivity of sodium with water, without the need to modify the reactor operating parameters: the core inlet and outlet temperatures remain unchanged and the design of the nuclear island is impacted only for the sodium-gas heat exchangers which replace the steam generators and for the operating of accident transients (lower thermal inertia, removal of the risks of sodium-water reaction, addition of problems specific to pressurised gas tanks and pipes).

- An approach which still relies on the use of a water-steam Rankine cycle, but with the objective of significantly reducing the probability of occurrence of a sodium-water reaction and drastically limiting the potential consequences (practical elimination of consequences on the nuclear part of the facility).

Note: Steam generators are the main place in an SFR where the risk of sodium-water reaction exists. However, whatever the power conversion system selected, an approach of prevention of this risk (in particular concerning the emission of hydrogen and its explosive reaction with the oxygen contained in the air) will be necessary in several other parts of the facility: "cleaning" of the reactor components and of the used fuel subassemblies, premises where sodium pipes or capacities are present and in which water (weather, leakage, etc.) may also appear, in particular during maintenance or dismantling operations.

3.1.3.1. BRAYTON CYCLE POWER CONVERSION SYSTEM

The studies carried out on a Brayton cycle gas power conversion are aimed at assessing the industrial feasibility of such a system in the temperature and pressure conditions considered for this application, the performance (among others, in terms of efficiency) and its compatibility with a nuclear island (impact on safety, security and radiological protection).

The impact on efficiency can be very different depending on the selected gas. Selecting supercritical CO₂ could make it possible to achieve high performance (efficiency above 40%, of the same level as a water-steam cycle) and significantly reduce the site coverage of the power conversion system. However, this cycle is very innovative, it requires studies to stabilise the operating point and it has never been implemented. There is also a chemical interaction between CO₂ and sodium. The use of supercritical CO₂ is therefore considered as a long-term option; development studies are being continued within the GIF in an international cooperation framework.

For short-term development, the selection fell on a 180 bar nitrogen cycle (with operating temperatures between 330°C and 530°C). Today, this power conversion system takes advantage of all the studies carried out in the years 2000 for the gas-cooled nuclear reactor projects of the HTR or VHTR types, including the Antares project supported by Areva, as well as the studies on conventional gas turbines. Therefore, CEA thinks that it is possible to consider this type of cycle for an SFR, considering however that this is a major industrial innovation for a 600 MWe turbine. The net efficiency of the power station is assessed between 37 and 38%, which remains above the efficiency level of the reactors currently in operation. It is also possible to design a set of modular turbines of the same type, but with a smaller size.

The use of a gas power conversion system (which, *de facto*, removes the risk of sodium-water reaction) does not make it possible to avoid the use of the sodium secondary system, as it is necessary to keep a barrier against any source of gas and against any pressure stress for the primary system, in order to comply with the safety objectives associated with the core.

The first assessments of the consequences of transients on the primary system, for an initiating event located on the tertiary system and impacting the primary and secondary systems, show that the consequences of transients of loss of tertiary cooling are lower for a gas power conversion system than for a water-steam power conversion system.

3.

PRIORITY IMPROVEMENT AREAS AND ASSOCIATED R&D PROGRESS

Preliminary studies have been carried out on the design of turbomachines (turbine, compressors). The design of the turbine remains particularly difficult, but there is no technological obstacle identified. A first model of the architecture of this gas power conversion system was also made for Astrid (see Figure 3.6). It does not reveal any technological impossibility concerning the design of all the components; however, the roadmap for the commissioning of a gas power conversion system of significant size (approximately 600 MWe), will have to be consolidated, as there have never been any similar facilities with power exceeding a few MWe built all over the world. This conversion system will therefore be a technological demonstrator itself.

Due to their very innovative nature, sodium-gas exchangers are the real technological challenge for the gas power conversion system and therefore they are the critical components of the system. A compact type exchanger technology (see Figure 3.7) is a promising way in terms of technical, economical and safety performance, but studies still have to be carried out concerning the qualification of the assembling process and the means for inspection during manufacturing and for in-service monitoring.

A backup solution is studied at the same time, with a more conventional, "shell and tubes" type, heat exchanger technology which would significantly simplify the manufacturability and inspectability of the component, however at the cost of a lower thermal compactness (less good heat exchanges), which would directly impact the number and size of the exchangers as well as the overall facility.

The design phase for this type of compact, non-standard exchanger for a reactor requires to know a certain number of parameters, in particular the exchange and friction correlations suitable to correctly describe the exchange geometries of the compact exchangers studied, that is to say Printed Circuit Heat Exchangers (PCHE) or Plates Fins Heat Exchangers (PFHE). These characteristics have a direct effect on the size of the components and on the input data for the thermomechanical analysis. An experimental loop, named DIADEMO-Na, is being commissioned in the CEA centre in Cadarache to acquire heat exchange data to validate the design studies. Furthermore, the acquisition of validated material data for the thermomechanical analysis, and the validation of the assembling process which is extremely important for the thermomechanical strength of the component, are important areas in the current R&D programme.

In the current state of the studies carried out jointly with Alstom and Areva, no redhibitory feasibility issue has been identified; however, the technological challenges for the sodium-gas exchanger and the turbine are taken into account. Until now, no closed gas Brayton cycle energy production facility has been operated on an industrial level, except a few facilities of small power in Switzerland and Germany, with low efficiency (~30%), the bigger one being the 50 MWe facility of Oberhausen (Germany) operated during the 1980's. If these perspectives are confirmed, a technological demonstration of the same power level will be necessary before a nuclear application can be considered.

FIGURE 3.6: EXAMPLE OF A MODEL OF TERTIARY SYSTEM OF A NITROGEN POWER CONVERSION SYSTEM

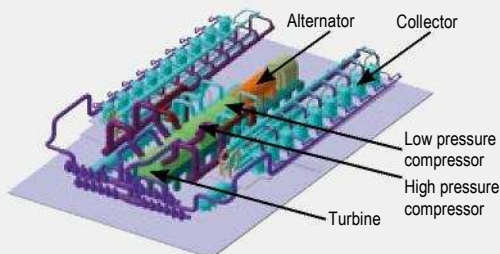
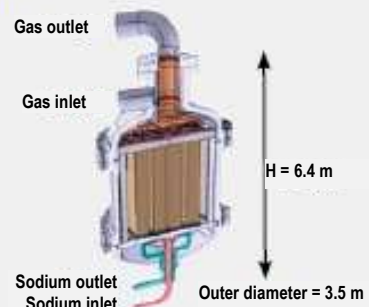

FIGURE 3.7: PROPOSAL OF DESIGN OF A COMPACT AND MODULAR SODIUM-GAS EXCHANGER



3.1.3.2. WATER-STEAM RANKINE CYCLE POWER CONVERSION SYSTEM

For a water-steam power conversion system, the design objectives are as follows:

- reduce the risk of sodium-water reaction through the robustness of the concepts as regards the failures of the walls between sodium and water and as regards their evolution kinetics,
- limit their consequences by reducing the source term through the implementation of early detection systems and through the limitation of the loads on the structures,
- reduce the costs by simplifying the concept and the routing of the pipes and through the control of the manufacturing processes.

The studies associated with the minimisation of the risk of sodium-water reaction are based on different technological options and associated materials, with the three following areas (see Figure 3.8):

- Comparison of the performance of the various steam generator families studied:
 - Helical steam generators; this is a mature option with the experience feedback from Superphenix, the A800 material is well-known, but this option still remains to be improved in particular as regards in-service inspectability, manufacturability and control of consequences in case of sodium-water reaction;
 - Straight tube steam generators, with a low expansion coefficient material (type 9Cr) for the tubes, and variants to manage expansions (bellows or loops); this option has a simplified design, but the behaviour of the 9Cr material is under assessment in case of sodium-water reaction, and the experimental database associated with the materials needs to be completed. Tests are in progress with the Japanese and Indian partners;
 - Reverse steam generators (sodium flows inside the tubes, while water flows outside); one of the major interests of

this option is that it is possible to limit the effects of a possible sodium-water reaction to only one tube, without propagation to the other tubes. However, the lower maturity of this option requires significant technological development as well as innovative solutions for the inspection of the tubes.

- Improvement of the computation models and codes, and integration of data concerning new materials (9Cr) and new design options taking the different phenomena into account (in particular as regards the reverse steam generator option);
- Improvement of the performance of the sodium-water reaction detection systems, with the objective of making sure that the initial leakage can be detected before the adjacent tubes result perforated by a local erosion-corrosion effect (a phenomenon called “wastage”) or by a swelling-bursting effect:
 - Assessment of the performance of electrochemical sensors, whose principle is based on the difference of hydrogen concentration between the liquid sodium and a reference electrolyte which generates an electric signal. Promising tests were carried out in 2008 and 2009 in Phenix on prototypes supplied by the Indira Gandhi Centre for Atomic Research (IGCAR).
 - Assessment of the performance of acoustic detection techniques: a passive technique based on the detection of noise generated by the resonant oscillations of the gas bubbles, and an active technique which analyses the acoustic attenuation due to the presence of a gas phase within the liquid.
 - Improvement of signal processing.

Concerning the limitation of consequences, the objective is to limit the losses of integrity of the steam generator casing, the secondary system and the intermediate exchanger, in order to make the safety demonstration robust. The modular steam generator is an assessed design option for which the objective is to verify that the integrity of the casings of the secondary system components will be maintained in case of failure of all the tubes.

FIGURE 3.8: DIFFERENT STEAM GENERATOR TECHNOLOGIES

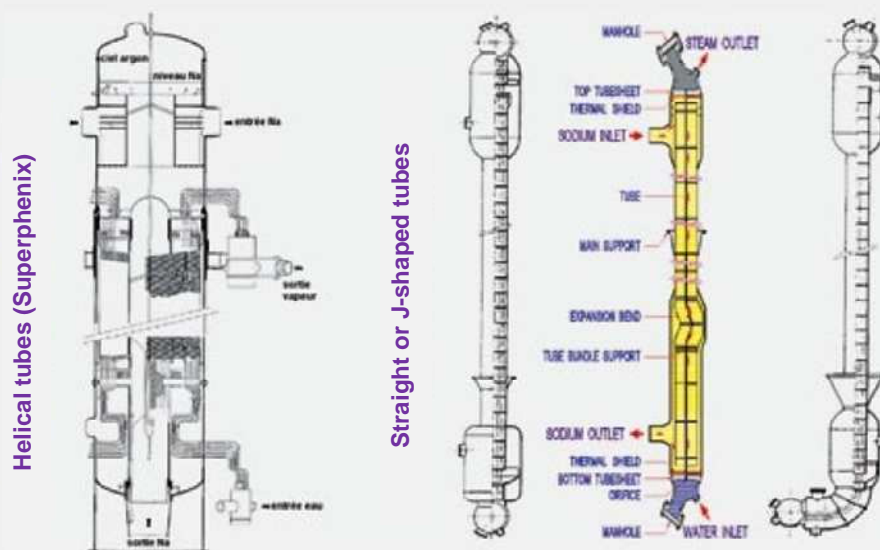

FIGURE 3.9: EXAMPLE OF A MODEL OF MODULAR STEAM GENERATOR

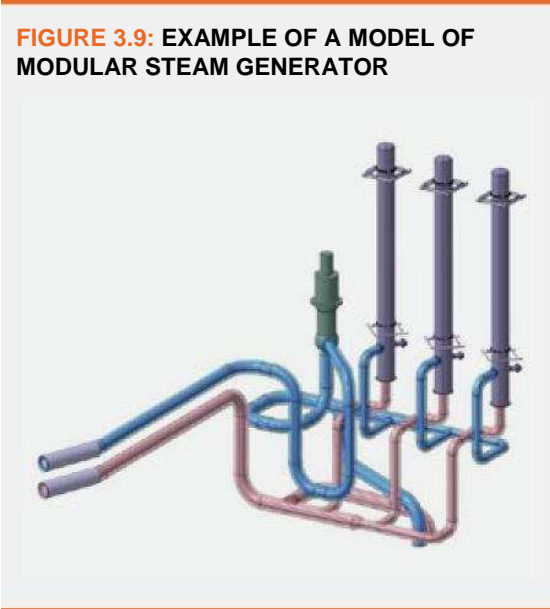

Figure 3.9 illustrates an example of a modular steam generator composed of 3 modules integrated into a secondary system with its sodium discharge tank and with the secondary system circulation pump.

3.1.4. SODIUM LEAK DETECTION

Apart from the monitoring of the core in the primary system, one of the applications for which improvements are expected is leakage detection, both for safety (risk of sodium fire) and availability (reliability of the detection system). Compared to the techniques previously used, CEA and its partners are exploring several innovative techniques with the aim to significantly improve the time necessary to detect and locate a sodium leak. For example, we can mention optical fibre based techniques, detection integrated into the coolant (CEA patent for a sodium leak detector multilayer coolant, offset coolant, etc.) or laser techniques (Laser Induced Breakdown Spectroscopy). During the AVP2 phase, these technologies will be compared to select the most efficient ones, in particular based on experimentations in progress in CEA facilities.

3.2. HIGHER AVAILABILITY THAN FORMER SFRs AND REDUCED SHUTDOWN TIMES

As regards reliability, the objective for the 4th generation systems is to obtain an availability factor of the same level as the standards for a production power plant, which means typically approximately 90%. This objective is ambitious for SFRs, and it requires significant progress in in-service inspection techniques for the primary system and the exchangers or steam generators, in the possibilities of quick replacement of primary components and in the development of a high-performance fuel handling system.

The objectives associated with this field of innovation mainly concern the following:

- Improvement of instrumentation performance for detection and location of sodium leaks;
- In-service inspection and reparability;
- Reduction of the shutdown periods for fuel reloading thus requiring improved handling system design. The improvement of the speeds for subassembly handling operations, which must be carried out in sodium up to an intermediate storage tank to integrate, in particular, the fuels containing minor actinides (warmer than standard subassemblies), the reliability of the technologies proposed and the preventive detection of failures will be criteria for selection;
- Reduction of shutdown periods for replacement or extraction of components (for inspection, ten-year maintenance, repair, etc.).

3.2.1. INSTRUMENTATION AND INSPECTION, MONITORING AND REPAIRABILITY

For safety reasons, CEA selected a pool type concept at the beginning of the project. This option has advantages (minimisation and simplification of the structures and the containment to be inspected) and drawbacks (larger dimensions, obstructed access areas) as regards the inspectability of structures. The inspectability of components in sodium is difficult due to the opacity of sodium and the need to keep it at a sufficient temperature so that it remains liquid (at least 150°C) and the need to keep it isolated from air. For Phenix and Superphenix, the prevention of failures of structures important to safety was based on a large design margin and a strict quality of construction; in-service inspection capabilities had been developed during the project or during its operation for the areas whose failure was likely to have consequences on the safety of the reactor (the core supporting structures in particular).

Beyond the principle used in former projects, the objective in this field is to rely on the experience feedback of the “Phenix lifetime extension” project and to take the inspection of the internal structures of the reactor block into account as from the design by providing the access points and the structure adaptations which will make the implementation of technologies (either existing or under development) easier. As applicable, these inspection technologies may be carried out from the outside or from the inside of the reactor. They will mainly use optical or ultrasonic methods. Selection will be made according to the design of the primary system. The amplitude and frequency of these inspections will be defined so as to comply with the safety objectives and with the objective of reactor availability demonstration. For all the studied architectures, the inspectability of structures in sodium will be one of the major criteria for selection.

FIGURE 3.10: HIGH-TEMPERATURE ULTRASONIC TRANSDUCER TESTING MOCK-UP



As many reactor structures as possible (above core structure in particular, and the components for which a service life of 60 years still cannot be demonstrated today) will also have to be made repairable (or replaceable on an exceptional basis).

Significant progress in terms of inspection and repairability capabilities is expected for the future SFRs, even if the experience feedback from the operations performed in Phenix and Superphenix already contains a large quantity of data and results which will have to be taken into account as from the design of future reactors.

Therefore, since 2007, the R&D programme has been covering a wide area, from the design of the reactor so that the internal structures allow development of instrumentation (sensors, signal processing, etc.) in various operating conditions (shutdown states, power states, behaviour in neutron flux etc.) to the development of efficient carriers in a sodium environment at temperatures of approximately 200°C and the development of repairability tools (welding, etc.) in this environment.

Without trying to be exhaustive, we can mention a few examples of results concerning, for instance, the progress made in the field of inspection:

- High-temperature ultrasonic transducers have been manufactured and tested in sodium environment on a mock-up to assess the impact of the internal structures of the primary vessel on the quality of the measurements (see Figure 3.10).
- As regards the developments in robotics, adaptations are being performed on carriers to operate in environmental conditions compatible with those of an SFR, and these adaptations will be tested in the sodium test loops of the Papirus platform (see para. 8.2.). In terms of repairability, promising results have been obtained both for laser cleaning and laser welding (see Figure 3.11).

3.2.2. FUEL SUBASSEMBLY HANDLING AND CLEANING

Handling of fuel subassemblies is a major challenge as it has a significant impact on the duration of the outage periods for reloading or rearrangement of the core, and therefore on the

FIGURE 3.11: LASER CLEANING THEN WELDING ON SODIUM WET PLATE



reactor's availability factor. The selection of the design options is based on the search for the best compromise between performance in terms of timing, safety or impact on the compactness of the nuclear island and the cost of the systems.

Main principles:

The function of the fuel handling system is to transfer and manage the fuel within the nuclear island, from the time it enters the nuclear facility to the time it is removed after its period inside the reactor.

There are three main types of fuel handling (see Figure 3.12):

1. In-vessel handling of the reactor fuel subassemblies. The main operations to be carried out for in-vessel handling are as follows:
 - Installation of new subassemblies inside the core through an in-vessel receiving position,
 - extraction of irradiated subassemblies from the grid to an in-vessel receiving position,
 - rearrangement of the core, with transfer to internal storage area if applicable.
2. Loading/unloading system. This concerns the operations of insertion, after conditioning, of new fuel subassemblies into the vessel down to the receiving position, and the operations of extraction of used subassemblies from the vessel, from the receiving position to the next processing position.
3. Ex-vessel handling, which includes all the operations carried out on fuel subassemblies out of the reactor vessel, that is to say:
 - receipt, inspection and conditioning of new subassemblies before their insertion into the reactor vessel;
 - displacement of irradiated subassemblies, after extraction from the vessel, between the different stations of the handling system;
 - storage of irradiated fuel subassemblies in an external storage area, if applicable, before cleaning;
 - irradiated subassembly inspection and cleaning operations;
 - storage of subassemblies, if applicable, before transfer for reprocessing.

FIGURE 3.12: SCHEMATIC DIAGRAM OF THE FUEL HANDLING SYSTEM

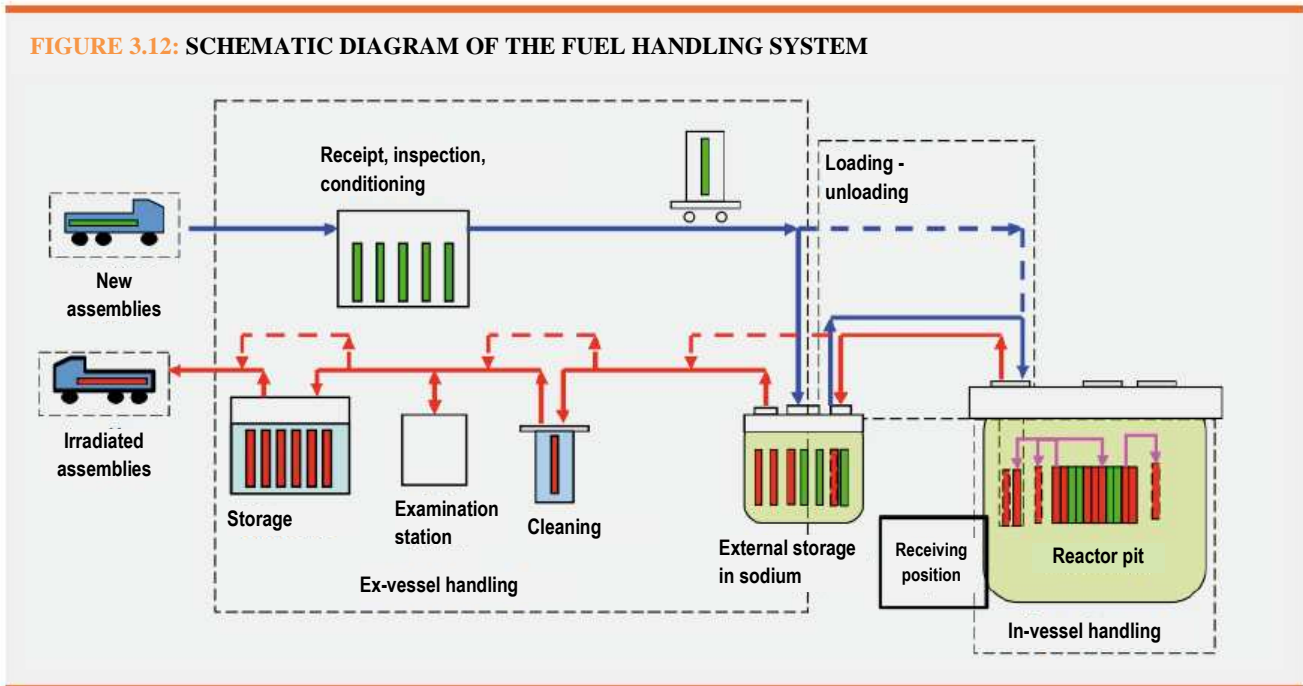

A search for innovations has been carried out since 2007 to develop means which will significantly increase the handling speeds and means which will allow handling of fuels subassemblies containing minor actinides. Figure 3.13 illustrates an example of design of a “mixed” system composed of an in-sodium ramp type primary handling system associated with a system to swap new subassemblies and irradiated subassemblies in order to improve the speeds, all these systems being combined with a corridor filled with gas for access to the external storage area.

As regards the availability in the secondary handling system, one of the critical paths is the cleaning process (until now, this process involves water spraying in carbon dioxide) which must allow the processing of fuel subassemblies having a residual power up to 7.5 kW. The experience feedback from Phenix and Superphenix showed areas of improvement in terms of operation, processing speed and robustness of the process.

Innovative cleaning processes have been tested and showed a promising potential. These processes are intended to increase the immersion speeds by adding mineral salt into the aqueous solution so as to moderate the sodium-water reaction kinetics. Furthermore, such a process is rather similar to the currently used process and, as a consequence, it should require few modifications in the design of the cleaning pits.

FIGURE 3.12: PRESENTATION OF THE FUEL ASSEMBLY HANDLING AND CLEANING SYSTEM

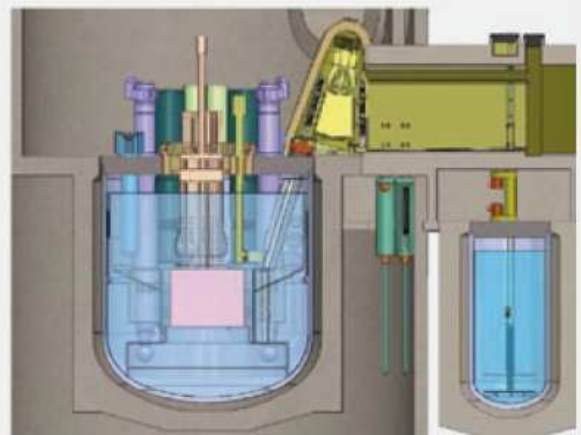

4.

SPECIFICATIONS AND SAFETY OBJECTIVES OF ASTRID	33
4.1. Astrid specifications	33
4.2. General safety objectives	33
4.3. General safety orientations	34
4.4. Safety orientations in the design phase	34
4.5. Integration of internal and external hazards	35
4.6. Orientations taken to ensure the safety functions	35
4.6.1. "Reactivity mastery" function	35
4.6.2. "Heat removal" function	36
4.6.3. "Radiological confinement" function	36
4.7. Orientations regarding severe accidents	36

4.

SPECIFICATIONS AND SAFETY OBJECTIVES OF ASTRID

4.1. ASTRID SPECIFICATIONS

The main objectives of the Astrid specifications are summarised below. The resulting requirements are detailed in Chapter 5.

The main objective of Astrid is to prepare the industrial deployment of 4th generation SFRs. Given the experience acquired with formerly operated SFRs, Astrid must therefore demonstrate and qualify, on an industrial scale, the validity of the innovative options in the identified progress areas, in particular safety and operability. The deadline for the industrial deployment has not been defined yet and it will depend on factors which are still unknown today (resources, energy cost, intensity of the fight against global warming, interest of the public opinion, political context, etc.). Therefore, it would be logical to have accumulated at least ten years of Astrid operation before this industrial deployment, in order to take advantage of a sufficient experience feedback on the one hand and benefit from the industrial and R&D competences mobilised for Astrid on the other hand, before building the next industrial power plants.

Therefore, it will be necessary to extrapolate the characteristics of Astrid to future 4th generation industrial SFRs of higher power, in particular for everything related to safety. The size of the future industrial power plants still remains undetermined, but the maximum value of 1,500 MWe was selected for the project, for the extrapolation studies.

The Astrid design shall have certain flexibility so that more innovative options not implemented in the initial design can be tested during its entire service life.

The safety level to be reached for Astrid shall be equivalent to the safety level of the power plants which will be commissioned at the same period, that is to say in the 2020 decade. This reference corresponds to the best safety standards currently known. It stems from the level of the current 3rd generation PWRs, formalised in the recommendations issued by the WENRA association, and from the safety requirements expressed following the Fukushima accident.

In terms of availability, the objective of the 4th generation system is to have an availability factor typically above 90% for a production power plant, which implies to allocate 5% for schedule shutdowns and to set, as a design objective, a design reliability such that unscheduled shutdowns and any prolongations of scheduled shutdowns will also account for a maximum of 5% of the time. Because of its prototype nature, the target availability factor of Astrid will be 80%, after deduction of experimental programmes.

In an approach for a sustainable use of nuclear energy, the aim of Astrid is to be isogenerating without radial breeder blankets. This provides this project with certain flexibility (low conversion, isogeneration, or breeding) for better adaptation to the various needs of future fast neutron power plants.

In the end, when this type of power plant becomes prominent in the fleet of electricity production plants, they will have to be able to carry out network follow-up. This requirement is not taken into account in the conceptual design phase of Astrid, given its power and the fact that it is a technological demonstrator. However, this requirement for power plants will be taken into account in the extrapolability tests which will be performed with the Astrid design option selections, so that this type of reactors can meet the needs of distribution system operators during its industrial deployment phase.

Future power plants will have to be designed for a service life of 60 years. The objective is the same for Astrid, however, with the currently available data, it may not be possible to guarantee this design as from the start of the reactor. Therefore, it is planned to guarantee a service life of 40 years, with a possibility of service life extension based on future R&D, the experience acquired with Phenix materials and the data which will be collected during the operation of Astrid.

Finally, the economic aspect must not be forgotten. Astrid shall allow an assessment of the future investment and operating costs in order to ensure certain planned competitiveness for the investors of series power plants. All this in a general vision of a fleet comprised of 3rd and 4th generation reactors, with an objective of general economic optimisation of the production of electricity and an objective of complete closed cycle for nuclear fuels, in comparison to the forecast concerning the cost of other energy sources (water reactor + cost of uranium + cost of used fuel management, fossil energy + CO₂ processing, renewable energies, etc.).

4.2. GENERAL SAFETY OBJECTIVES

The purpose of this paragraph is to present the first safety orientations which will be used to define the design option studies and the associated safety analyses as from the conceptual design phase of Astrid.

The main safety objectives are defined according to the various categories of incident and accident situations which can occur to the facility while complying with the fundamental principle of nuclear safety: a situation must be all the less plausible as its potential consequences are severe.

These objectives are detailed in the safety orientations report (DOrS) submitted to the ASN (French Nuclear Safety Authority) in June 2012.

For the discretisation of the risk, the situations formerly identified as “beyond design” must be taken into account for Astrid. For this purpose, the rules for study, the design orientations and the objectives associated with these situations have been specified. In particular, three additional fields have been identified in addition to the operating categories:

4.

SPECIFICATIONS AND SAFETY OBJECTIVES OF ASTRID

- In the field of “situations of prevention” (SP), where many equipment items are assumed to have failed, prevention will have to be improved through a favourable natural behaviour of the core in these situations, and the absence of cliff-edge⁹⁹ effect will have to be ensured with respect to the “design” situations;
- In the field of “situations of mitigation” (SM), the core meltdown situation is assumed and taken into account. Devices are designed and implemented to comply with the objective of taking only population protection measures which will be limited in terms of duration and extent, without early or significant releases;
- In the field of “practically eliminated situations” (SPE), an objective of demonstration of the highly improbable nature of such situations has been set, based on the implementation of specific provisions and on substantiation through suitable studies, or based on what is “physically impossible”.
- the general safety principles universally applied: principle of barriers and associated systems, principle of defence in depth. In the application of this principle, it is necessary to ensure, by design, that the various levels will have sufficient independence. In particular, it is necessary to take the complete core meltdown accident into account as from the design phase for the fourth level of defence in depth; this accident must be assumed despite the high level of prevention obtained by design;
- safety technical principles resulting from the progress made over time in the nuclear sector (single failure criterion, rules of cumulative events, method of the lines of defence etc.);
- integration of the experience feedback from the design and operation of former SFRs, such as in-service inspection requirements;
- specific design orientations to reinforce the robustness of the safety demonstration.

4.3. GENERAL SAFETY ORIENTATIONS

The general safety orientations selected for Astrid which prefigure, as much as possible, the orientations of the future SFR system are as follows:

- Greater independence of the levels of defence in depth than what usually prevailed in the design of former SFRs;
- Improved severe accident prevention which, beyond the action of the safety systems (conventional approach), improves the natural behaviour of the facility; this must be taken into account as from the design phase, in case of failure of the safety systems;
- In addition to the prevention measures, integration of the complete core meltdown accidents for the design and dimensioning of provisions aimed at mitigating any potential consequences;
- Handling of the risk of chemical toxicity in addition to the radiological risk;
- Integration of the experience feedback from the Fukushima accident, including the notion of “hard core”, taking the specificities of SFRs into account;
- Integration of malicious acts, in particular in the design of the safety provisions.

4.4. SAFETY ORIENTATIONS IN THE DESIGN PHASE

The application to the Astrid project of the safety orientations in the design phase is based on the following:

In addition of the fundamental principles, the design orientations set for the project are listed below (non-exhaustive list):

- Design of the core. The objective is to minimise the risk of recriticality within the scope of the integration of core meltdown situations (of local and general origin). However, this risk is taken into account in the severe accident studies, within the scope of the defence in depth. Therefore, the objective is to reduce the released mechanical energy likely to stress the containment;
- Design of the nuclear island. The objective is to practically eliminate the total and prolonged loss of the “decay heat removal” function. As this case concerns the decay heat removal systems, the improvements considered must make it possible to:
 - introduce more “geographical diversification” to face the risks of common mode failures not covered by the current “equipment diversification” and “functional diversification”;
 - take into account the possible damage of decay heat removal systems in a severe accident scenario, to guarantee cooling after a severe accident (for example, a core catcher cooling system).
- Design of the facility / use of sodium. The chemical risk associated with the use of sodium is examined from two points of view:
 - hazard to the nuclear island, concerning the radiological risk (e.g.: hazard to barriers),
 - event likely to have direct consequences (e.g.: release of toxic aerosols into the environment caused by a sodium fire).

⁹⁹ – Cliff-edge effect: sudden alteration of the behaviour of a facility, caused by a very slight change in the scenario considered for an accident, and whose consequences will therefore get significantly worse.

In comparison with the previous SFRs, the main objectives are as follows:

- better control of the risks of sodium leakage; for example,
 - Reinforce the application of the design and construction principles: use the experience feedback and qualify the materials which will be used, limit the welds and stresses through design, ensure a high level of quality of construction,
 - improve the detection and inspection means,
 - integrate the principle of “detection of leakage before failure” into the design studies of systems and detection means,
- combine the radiological containment measures and the barriers with other provisions concerning sodium risks. As sodium risks may be a source of hazard for the radiological safety provisions, chemical and radiological risks shall be separated as much as possible.

As from the preconceptual design stage, the safety of the reactor in the shutdown states is given the same care as the safety of the reactor in power state, and the safety of the whole facility is given the same care as the safety of the reactor.

Particular care is given to falling loads, in particular during handling operations, and more specifically in the area above the slab.

Equipment items important to safety shall be inspectable. Concerning the equipment necessary to keep the reactor in a safety shutdown state, additional steps are taken depending on the accessibility level, the reparability level and the time necessary for repair (ISIR).

Similarly, the possibility to unload the core within a reasonable time, compatible with the safety demonstration, and in degraded situations, is a selected orientation.

For the more frequent initiators, after verifying that the detection/protection means are sufficient, we try to obtain by design a natural behaviour of the facility favourable enough to prevent a severe accident despite the very pessimistic assumption of failure of the normal shutdown systems.

By design, the mitigation means related to the containment and cooling of the corium shall not be significantly impacted by the mechanical effects of a severe accident.

4.5. INTEGRATION OF INTERNAL AND EXTERNAL HAZARDS

General case: hazards have always been dimensioning loading cases for SFRs, in particular earthquakes and interactions between sodium and water or air. Additional orientations are selected for Astrid concerning the following:

- Combination of hazard with potentially concomitant events (i.e. other internal or external hazards, incidents, accidents).
- Considerations regarding hazards of a higher level than the level selected for the design.
- Reinforcement of the application of the principle of defence in depth as regards internal hazards.

Particular case of earthquake: one important orientation regarding earthquake is to consider, for the analysis related to certain systems (post-Fukushima hard core), seismic levels higher than those selected for the general design of the facility. These systems include, in particular, certain parts of the shutdown systems and cooling systems. A system for automatic shutdown upon earthquake detection is provided for.

Particular case of aircraft crash: one of the design orientations concerning aircraft crash, consists in designing the equipment to prevent a severe accident having direct effects caused by an aircraft crash. This initiator will not lead to complete core melt down.

Particular case of malicious acts: the study of malicious acts is taken into account as from the early stage of the design of Astrid, in accordance with the law (see para. 5.3).

4.6. ORIENTATIONS TAKEN TO ENSURE THE SAFETY FUNCTIONS

4.6.1. “REACTIVITY MASTERY” FUNCTION

Among other design orientations related to reactivity mastering, it is planned to implement automatic shutdown systems in case of abnormal variations of reactivity.

For the shutdown transients and shutdown states, reactivity mastery is mainly based on compliance with a list of antireactivity criteria defined for the following:

- Simple handling mistakes,
- Starting conditions,
- Possible needs in shutdown kinetics for rapid transients,
- Automatic actions for switching to a safe shutdown state,
- Case of sodium void or draining in a configuration of fallen rods,
- Case of compaction (or shaking with radial expansion movement followed by compaction) of the core, including with clad failures,
- Risks of propagation of a local degradation of the core (local meltdown).

In comparison with former reactors, the points below are specifically studied for Astrid:

- Possible additional provisions are considered to ensure reactor shutdown in case of total failure of the two automatic shutdown systems. These provisions are considered in the case where the design of the core would not make it possible to neutronically smother the core through its own effects in thermal reactivity feedback. These provisions are also aimed at keeping the reactor in a safe state in the long-term, as applicable through actions by the operator;
- In case of severe accident, one of the main objectives related to reactivity control is to eliminate the risk of energy accident likely to damage the containment and the decay heat removal systems. In particular, the design orientation consists in minimising the risks of recriticality;

4.

SPECIFICATIONS AND SAFETY OBJECTIVES OF ASTRID

- Situations of very fast reactivity insertion are practically eliminated. These situations can make the action of automatic shutdown systems ineffective or cancel the natural behaviour of the core and of any additional devices or the effect of severe accident mitigation provisions. These situations may be, for instance: a sufficiently big gas bubble passing into the core, collapse of the core supporting structure, fast core compaction, etc.

4.6.2. "HEAT REMOVAL" FUNCTION

For the Astrid project, the main orientations selected to ensure this function are as follows:

- Evacuate the residual power of the reactor, including in configurations with loss of forced flows;
- Guarantee that components important to safety will be fully available, in particular when the reactor is in power operation state;
- Prevent excess cooling in particular at the exchangers of the cooling systems during shutdown;
- Remove the residual heat present on the handling system (until the used fuel external storage area);
- Ensure cooling of the core and the reactor structures, including in case of leakage of the main vessel;
- Cool the core in case of suspected local blockage. This type of function may have an effect on the selection of the automatic shutdown procedure;
- Guarantee continuous cooling in situations following a severe accident. The objective is to ensure the correct routing of the molten parts towards the core catcher and cool them.

In particular, the objective is to practically eliminate, by design, the situations of complete and prolonged loss of the decay heat removal function.

4.6.3. "RADIOLOGICAL CONFINEMENT" FUNCTION

The main orientation regarding the containment function is to limit, as much as possible, any radioactive release, for all the operating conditions and for all assumed situations whose consequences are taken into account. Anyway, these releases shall be such that:

- Excepted situations of complete core meltdown (SM), measures outside the site (containment, evacuation of population) will not be required;
- In case of complete core meltdown accident (SM), only population protection measures limited in terms of extent and duration shall be permitted.

For the reactor part of Astrid, several containment design options are under study. The general orientations are as follows:

- containment of radioactive products, including gases released by the reactor protection valves;
- special care concerning the risks of containment bypass;
- protection of the containment equipment from external hazards (e.g.: aircraft crash);
- integration of the radiological risks and of the sodium risks.

These orientations shall be extended and adapted to the other source terms of the facility, in particular regarding handling and storage of fuel elements.

4.7. ORIENTATIONS REGARDING SEVERE ACCIDENTS

The main orientations regarding severe accidents can be described as follows:

- Take severe accident and its consequences into account through the design and dimensioning of the facility, despite a high level of prevention;
- Demonstrate that no plausible accident sequence generated by identified initiator events will lead to a situation of complete core meltdown;
- Within the scope of the 4th level of defence in depth, define and study the complete core meltdown from situations which are representative of the various families of initiator events, in order to confirm the low energetic nature of the severe accident;
- Design and size the mitigation provisions separately from the severe accident studies, in order to define significant safety margins related to the mechanical loading aspect.

5.

REQUIREMENTS TO BE COMPLIED WITH AND BASIC CHOICES FOR ASTRID	39
5.1. Strategic requirements	39
5.1.1. Astrid's power	39
5.1.2. Astrid's potential of transmutation demonstration	39
5.1.3. Astrid's experimental potential	41
5.1.4. Resistance to proliferation	41
5.2. Safety requirements.....	42
5.2.1 Prevention and mitigation of severe accidents	42
5.2.2. Decay heat removal	42
5.2.3. Presence of a molten core catcher	42
5.2.3. Inspectability of structures	42
5.2.4. Sodium risks	42
5.3. Security requirements	43
5.4. Operating requirements	43

5.

REQUIREMENTS TO BE COMPLIED WITH AND BASIC CHOICES FOR ASTRID

5.1. STRATEGIC REQUIREMENTS

5.1.1. ASTRID'S POWER

The main objective of Astrid is to prepare the industrial deployment of 4th generation SFRs. Given the experience acquired with formerly operated SFRs, Astrid must therefore demonstrate and qualify, on an industrial scale, innovative options in the identified progress areas, in particular in terms of safety and operability.

Therefore, it will have to be possible to extrapolate Astrid's characteristics to future 4th generation, higher power industrial SFRs, in particular for all subjects related to safety. The size of future industrial power plants still remains undetermined, but the project selected a value of 1,500 MW-electrical for the extrapolation studies.

The choice of the power is a compromise between the representativity of Astrid for the future commercial power plants and its nature as a technological demonstration which has to give it a certain level of flexibility. The investment and operating costs are also to be taken into account.

As regards the core, the validation of the options requires a power above 400 MWe for the technological demonstrator.

The economic analysis brings decision-making elements concerning the profitability of the project: with reasonable assumptions on the selling price of electricity and the availability factor of a technological demonstrator, the operating costs will be covered as from a power of approximately 400 MWe. Selecting a higher power will provide the technological demonstrator with a more robust business plan, as the operating results will make it possible to reimburse a loan or fund experimental programmes.

These elements lead us to select a power of 1,500 MW thermal for the reactor, which means an electrical power of approximately 600 MWe. A sensitivity analysis of this power will be carried out during the next design phases of the project. This analysis will include a more thorough economic analysis and it will take possible threshold effects into account as regards certain design choices, in particular concerning the safety demonstration.

5.1.2. ASTRID'S POTENTIAL OF TRANSMUTATION DEMONSTRATION

The act dated 28 June 2006 on the management of radioactive materials and waste requires "to provide by 2012 an assessment of the industrial prospects of those systems [separation and transmutation of long-lived radioactive elements] and to commission a prototype facility by 31 December 2020". Astrid shall continue, on an industrial scale, the demonstration of its capability to recycle plutonium and uranium from used fuels and study the possibility to transmute minor actinides in order to reduce the quantity of nuclear waste.

This demonstration may be performed gradually with the introduction of minor actinides in the core, on different scales ranging from the experimental capsule containing one or more pins to a complete subassembly, or even a group of subassemblies.

The demonstration scenarios currently proposed concern the 2 transmutation modes, homogeneous in standard fuel and heterogeneous in minor actinide bearing blankets (MABB) (see Tome 2). The most ambitious scenarios lead to a demonstration, in the end, of balance between production and consumption of minor actinides. When applied to americium only, the balance between production and consumption leads to the irradiation of a complete rim of AmBB heterogeneous targets, or to loading of a few % of americium into the Astrid core, for the homogeneous mode.

For minor actinide transmutation fuels or targets, the behaviour in irradiation turns out to be different from that of standard fuels, mainly for the following reasons:

- the effect of minor actinides on the physical properties of the material (thermal conductivity, melting point, oxygen potential, etc.);
- the processes associated with minor actinide transmutation (in particular significant production of helium for americium);
- the particular irradiation conditions, which is more specifically true for the radial blanket areas for AmBBs¹⁰¹⁰, where neutron flux gradients are high and the linear power density is low.

The overall qualification approach simultaneously covers the fissile material, the fuel element (pin with cladding, fissile column and internal structures) and the complete subassembly (external structure, pin bundle with spacing wire).

¹⁰ – Americium bearing blankets.

5.

REQUIREMENTS TO BE COMPLIED WITH AND BASIC CHOICES FOR ASTRID

FIGURE 5.1: MATERIAL CYCLE FOR ASTRID

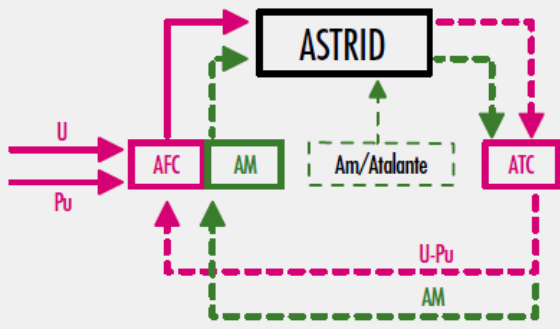

AFC: Core manufacturing facility
ATC: Fuel processing facility

This action is comprised of several phases from the design to the qualification of the product in its industrial environment, and including analytical validation and qualification of a prototype in reactor in representative conditions. These various phases will lead to irradiation experiments performed on various scales.

Given the level of knowledge reached (see Tome 2), Astrid may have the following functions, considering americium in priority then possibly neptunium (curium has excessive impacts on the design of the reactor and its involves issues which are very difficult to solve as regards the manufacturing and transport of fuels):

- In homogeneous mode, Astrid may perform irradiations of pins for a burn-up fraction and a linear power density representative of the expected standard irradiation conditions and with a stabilised manufacturing process. The qualification of the process would be carried out through irradiation of one or more subassemblies containing americium representative of the isotopy of used fuels;

- In heterogeneous mode, qualification of prototypes (pins, pin bundles) in the planned irradiation conditions in Astrid; the qualification of the process will require the irradiation of one or more subassemblies in the conditions of the material cycle of Astrid (see Figure 5.1).

Depending on the availability of the facilities of the cycle and the deadlines necessary for the examinations of the prototypes and industrial products in the hot laboratories, the various steps of the demonstration of transmutation in Astrid may be performed according to the schedule illustrated in Figure 5.2.

In order to determine the minor actinide transmutation capacity in Astrid, a preliminary analysis of the threshold effects, viewed from the reactor, has been performed. By “threshold effect”, we mean the limit values of minor actinide content in the core (both in homogeneous mode and heterogeneous mode) beyond which the design and safety demonstration of the core would have to be significantly modified. This analysis is based on the impact study related to the introduction of minor actinides (in homogeneous mode, in the entire core; in heterogeneous mode, in the form of targets located in the entire rim around the core) on the performance and safety of the Astrid reactor and on the design of the storage facilities, handling systems and transport packaging of the fuel subassemblies.

The parametric study on the initial contents in minor actinides (from 1% to 5% in homogeneous mode; from 10% to 20% in heterogeneous mode) allowed us to determine these minor actinide limit threshold values for the two transmutation modes. Americium, which is the main contributor to the thermal properties and the radiological toxicity of glass packages after decay of fission products, was dealt with in priority.

More precisely, the acceptability criteria of the parametric study concerned the following:

- The effect on the safety coefficients of the core;

FIGURE 5.2: STEPS OF TRANSMUTATION DEMONSTRATION IN ASTRID

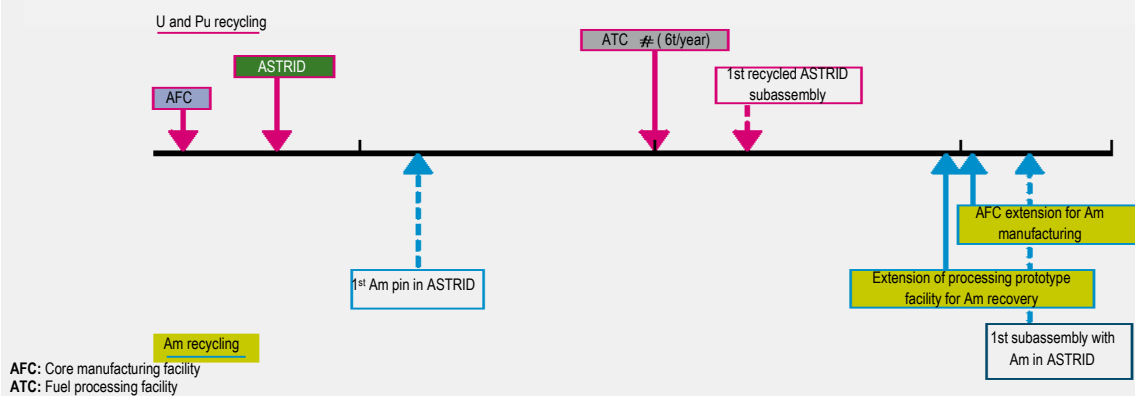

AFC: Core manufacturing facility
ATC: Fuel processing facility

- The power of the new subassemblies and targets in terms of limit values, for their transport;
- The necessary cooling periods so that the residual heat of the subassemblies and targets, after irradiation, comply with the limits stipulated for their handling in vessel, storage, cleaning and transport;
- The impact on radiological protection and the classification of radiological areas associated with handling operations.

Finally, the limit values for minor actinides to comply with the criteria defined for standard fuel, therefore without significant impact on the design of Astrid, are as follows:

- For Am only, a content of approximately 2% in homogeneous mode and 10% in heterogeneous mode;
- Np does not involve any particular difficulties and can replace a part of Am;
- Cm has significant impacts on the handling of new subassemblies and it is not selected for the demonstration scenarios in Astrid.

With these limit values, it is possible to reach a situation of balance between production and consumption of Am or even Np and overall weight of minor actinides in the Astrid core.

5.1.3. ASTRID'S EXPERIMENTAL POTENTIAL

After the shutdown of Phenix, there is no fast neutron spectrum irradiation reactor left in Europe. Astrid will fill this gap and provide with the possibility to carry out experimental irradiations in fast neutron spectrum, however without the same flexibility as a Material Testing Reactor.

This irradiation potential must be used to qualify:

- innovative options in the field of safety and operability;
- the increase in the performance of materials and the reference fuel of Astrid;
- the innovative materials and fuels for this system;
- the calculation codes implemented for the design studies.

The analysis of the experimental needs known today shows that it is necessary to have specific experimental devices to perform:

- irradiations of experimental subassemblies or of subassemblies which include capsules containing experimental pins, not requiring variation of the irradiation conditions or specific on-line instrumentation over time;
- irradiations requiring continuous physical measurements, in addition to the normal instrumentation of the core.

The know-how developed with Phenix will make it possible to meet these requirements.

On the other hand, the question of the installation of an irradiation loop for Astrid has formed the subject of an opportunity study. The conclusion of this study is that the implementation of such a loop as from starting is not selected, but reservations will be made for a possible installation later during the service life of Astrid.

Experiment preparation and post-irradiation examinations require specific facilities, in particular hot cells. The possibility to carry out non-destructive testing inside the hot cells, on the experimental pins and subassemblies, is extremely interesting in particular to quickly comply with the requests issued by the French Nuclear Safety Authority, especially for the purposes of the core monitoring and performance enhancement plan. This is the reason why Astrid will be equipped with hot cells. As regards destructive tests, these can be carried out in specialised facilities such as the active fuel examination Laboratory (LECA) of CEA-Cadarache.

Astrid is not planned to be used as a test bench for large technological components.

5.1.4. RESISTANCE TO PROLIFERATION

As regards non-proliferation, there is no problem to be faced as regards the use of Astrid and its associated cycle facilities in France, as France is bound by the international agreements it entered into in this field. Furthermore, the deployment of the SFR system on an international scale is considered only in cooperation with countries that have made sufficient commitments. However, a study is in progress to examine the possibilities for reinforcing the resistance of the SFR system to proliferation as from the design phase.

First of all, it is to be noted that a fast reactor operating in closed cycle only requires loading with depleted uranium. Unlike current reactors, a fast reactor therefore completely removes the need for fuel uranium enrichment (upstream phase of the cycle), which is a major advantage in terms of non-proliferation.

Second, SFRs fall within the scope of the issue of resistance to proliferation, for two reasons:

- on the one hand, they use MOX fuels with a high Pu content;
- on the other hand, they provide with the possibility to irradiate radial breeder blankets which can produce, depending on the conditions, Pu with an isotopic quality much sought-after by those involved in proliferation.

As regards the reactor, the first barrier is the implementation of guarantees (in the meaning of the IAEA guarantees). As a matter of fact, if an efficient surveillance process is implemented, handling of breeder blankets or swapping of a subassembly from the core with a different subassembly for proliferation purposes will be very difficult to perform.

In the case of 4th generation reactors, these guarantee steps must be provided for as from the design phase. This is already common practice in the design of LWRs and the cycle facilities in France and, as regards Areva, in the different projects of design and construction of nuclear facilities at international level. The identification of these guarantee steps will form the subject of a complete study, in relation with the IAEA, in order to find in which context these steps can prove to be fully efficient.

This will allow the IAEA to propose, as applicable, devices which will allow the safety and non-proliferation requirements to be complied with and the guarantees to be integrated as from the design phase of the reactor.



REQUIREMENTS TO BE COMPLIED WITH AND BASIC CHOICES FOR ASTRID

5.2. SAFETY REQUIREMENTS

The safety level to be reached for Astrid shall be equivalent to that of the power plants which will be commissioned at the same period, that is to say in the 2020 decade. This repository corresponds to the best safety standards currently known. It stems from the repository of the current 3rd generation PWRs, formalised in the recommendations of the WENRA association, and from the safety requirements defined following the Fukushima accident.

5.2.1 PREVENTION AND MITIGATION OF SEVERE ACCIDENTS

The major objectives in this field are the same as those defined in Chapter 3 as regards the complete sector.

- Reduction of the probability of severe accident, and in particular a core accident:
The most severe core damaging accident must have an annual rate of occurrence less than 10^{-5} per reactor per year, taking all the internal events and external hazards into account. An orientation value of 10^{-6} was selected as the frequency related to internal events.
- Integration of a core meltdown accident:
As regards the consequences for the environment in case of severe accident, the implementation of countermeasures outside the site must not be necessary over a long period. This objective is consistent with that presented by the GIF and by the WENRA association.

5.2.2. DECAY HEAT REMOVAL

The evacuation of the residual heat from the core is one of the three main safety functions to be ensured for nuclear reactors. The advantage of sodium-cooled fast neutron reactors (SFR) over pressurised water reactors (PWR) is that SFRs have a significant boiling margin in normal operation (more than 300°C) together with a high thermal inertia of the primary system.

Decay heat removal systems mainly use air as a cold source and they are based on natural convection, which allows the use of systems operating in passive mode.

In addition to the redundancy and the diversification of these systems, the requirement in this field is to practically eliminate the loss of the decay heat removal function.

5.2.3. PRESENCE OF A MOLTEN CORE CATCHER

One of the objectives of the studies of the Astrid core is to eliminate the complete core meltdown accident. However, the integration of a severe accident is made mandatory in accordance with the 4th level of defence in depth in order to comply with the recommendations issued by the WENRA association. The core catcher is a severe accident mitigation device which must contribute to ensuring the three main safety functions:

containment control, evacuation of the corium residual heat and reactivity mastery.

The installation of a molten core catcher is therefore integrated into the design of Astrid.

5.2.4. INSPECTABILITY OF STRUCTURES

The inspection of structures, and in particular those structures in sodium, is a difficult problem on sodium-cooled reactors. This is why a significant effort is made as from the conceptual design phase to develop in-sodium and out-of-sodium inspection machines. At the same time, the design choices are made taking inspectability into account, as for example the supporting structures and the sodium supplying structures of the core or the design of the slab. This will be described in more details in paragraph 6.5.

5.2.5. SODIUM RISKS

For the Astrid specifications, the objective is to reduce the probability of sodium fire (sodium-air reaction) and sodium-water reaction, and simultaneously to reduce the consequences thereof.

In addition to the safety principles mentioned in para. 4.4, as regards the sodium-air risk (importance of the design and of detection/inspection, implementation of the principle of leakage detection before failure, containment, limitation of consequences), several options must be evaluated and selected:

- for the sodium-water reaction, a gas power conversion system to replace the water-steam system, and modular or reverse steam generators (see para. 3),
- for the sodium-air reaction:
 - for the primary system, selection of the principle of pool type primary system (see para. 6.2.2), with inerting of the annular space between vessels,
 - for the external storage, concept of a building which will provide containment in case of accident,
 - above the slab: the pipes of the secondary sodium loops will be designed with a dual envelope, and leakage detection will be performed as close as possible. The limitation of potential hazards on this area is also under study (reliability of handling operations above the slab), together with the need for sectorisation or the need to fully inert this area,
 - selection of electromagnetic pumps, for which the absence of rotating parts and sealing devices (necessary on mechanical pumps) reduces the risk of sodium leakage.

The design options selected or under study to comply with all the requirements related to safety are presented in Chapter 6.

5.3. SECURITY REQUIREMENTS

Concerning the facility design phase, a thorough study will be carried out in order to take workers' safety into account on the following aspects:

- accessibility to workstations (during operation and during maintenance),
- steps taken to limit workers' exposure to hazardous materials other than radioactive materials (which form the subject of a specific ALARA approach),
- selection of materials for the protection of persons and of the environment,
- integration of the sodium risk,
- management of conventional waste.

This approach will be closely related to the Integrated Logistic Support (ILS) and Human and Organisational Factors (HOF) requirements.

Given the nature of the facility, the study of malicious acts is taken into account as from the design phase. This study will be based, in principle, on the approach and the set of threats specified by the National Safety Directive for the nuclear subsector.

Malicious acts will be integrated into the safety approach for the facility and each file (Safety Option Report, Preliminary Safety Report, etc.) will include a paragraph related to malicious acts which will refer to a specific classified file submitted to the safety authority.

The principle of defence in depth, which is a specific point in the protection against malicious acts, will be applied to the protection and control of nuclear materials. The premises in which Category I nuclear materials are stored will be equipped with different concentric physical protection barriers, from the outside to the inside.

Finally, the materials stored within the facility will be under the control of Euratom.

5.4. OPERATING REQUIREMENTS

Astrid must comply with the requirements for an industrial reactor in terms of reliability and availability. This requires the following:

- Increase in the duration of the cycles, which also implies an increase of the service life of the control rods in the reactor.
- Reduction of the duration of scheduled outages. The objective was set to 5% and significant effort is made on the fuel loading and unloading speeds.
- Reduction of the causes for unavailability, through design and reliability studies performed as from the beginning of the project. Generally speaking, the target for Astrid is an availability rate of 80%, not including the possible experimental programmes.
- Reduction of the duration of unavailability periods, by integrating into the design studies the issues related to maintenance. An integrated logistic support action is scheduled as from the preliminary design phase.
- Preservation of the investment by making the maximum number of reactor structures repairable (or replaceable).

- Reduction of operating costs: automation, fuel burn-up fraction, optimisation of the number of components subject to regulatory inspection, etc.
- Optimisation of the dosimetry, by integrating the experience feedback from the previous reactors, in which personnel exposure was very low.
- Waste management.
- Integration of dismantling into the design.

6.

ASTRID DESIGN OPTIONS FOR MAJOR FIELDS	45
6.1. Core and fuel	45
6.1.1. Fuel material	45
6.1.2. Cladding material	45
6.1.3. Fuel element	45
6.1.4. Core and subassemblies	46
6.2. Nuclear island	47
6.2.1. Principle of “clean” primary system	47
6.2.2. Pool type primary system	47
6.2.3. Presence of an intermediate circuit	47
6.2.4. Internal architecture of the main vessel	47
6.2.5. Core supporting structures	50
6.2.6. Reactor block closing slab	50
6.2.7. Neutron monitoring	50
6.2.8. Molten core catcher	50
6.2.9. Decay heat removal	51
6.2.10. Intermediate sodium loops	51
6.3. Power conversion system	52
6.4. Handling of fuel subassemblies	52
6.4.1. In-vessel handling.....	52
6.4.1.1. Installation of new subassemblies in the core and removal of irradiated subassemblies	52
6.4.1.2. Rearrangement of the core	53
6.4.2. Loading / unloading system.....	53
6.4.3. Ex-vessel handling	54
6.5. In-service instrumentation and inspection (ISIR)	54
6.5.1. Context and approach	54
6.5.2. In-service monitoring	55
6.5.2.1. Challenges of in-service monitoring	55
6.5.2.2. Examples	55
6.5.3. Periodical inspection	56
6.5.3.1. Challenges of periodical inspection	56
6.5.3.2. Example of interaction between the design and the inspection of the strongback.....	57
6.6. Instrumentation and control	57
6.6.1. Context and approach	57
6.6.2. Basic principles for the design of Astrid’s instrumentation and control system	58
6.6.3. Architecture elements for Astrid’s instrumentation and control system	58
6.6.4. Possible technologies for the instrumentation and control system.....	58
6.6.5. Perspectives	58

6.

ASTRID DESIGN OPTIONS FOR MAJOR FIELDS

The current choices in terms of design options are presented in this chapter. The major fields considered are as follows:

- Core and fuel
- Nuclear island
- Power conversion system
- Fuel handling
- Instrumentation in the core and inspectability & repairability
- Instrumentation and control

6.1. CORE AND FUEL

6.1.1. FUEL MATERIAL

The reference fuel for the Astrid core is mixed oxide (U, Pu)O₂.

In France, there is a significant experience feedback available, acquired for over more than forty years based on experimental programmes and monitoring programmes carried out in Rapsodie, Phenix and Superphenix (see Chapter 2). These experimental programmes and the accumulated experience feedback on the oxide fuel as well as on the cladding materials and the hexagonal tubes (manufacturing and irradiations) demonstrated that this fuel has an excellent behaviour up to very high burn-up fractions.

In terms of performance, world records were achieved in Phenix, by experimental subassemblies (BOITIX 9, which totalled 144 GWd/t, i.e. 156 dpa). This performance was reached while the number of cladding failures was kept at a very low level. Over approximately 150,000 fuel pins irradiated in Phenix during its 36 years of operation, only 15 “open” cladding failures occurred (none in Superphenix), half of which occurred on experimental pins irradiated beyond the “standard” characteristics.

6.1.2. CLADDING MATERIAL

The wanted material for the core of this system is a steel which is not susceptible to excessive swelling under irradiation, even for significant doses above 150 dpa, and which would allow very high burn-up fractions to be reached for the core (> 150 GWd/t_{ML}). This challenge is extremely difficult because the tight network of the fuel due to the selection of a small diameter of spacing wire requires very small swelling of the cladding under irradiation. The material considered to achieve this performance, for the system, is a ferritic or martensitic oxide dispersion strengthened steel (ODS steel).

Many development studies are in progress on ODS steels, but given the needs for the qualification of a new cladding material,

ODS steels will not be industrialised for the start of the Astrid technological demonstrator.

Consequently, for the first Astrid cores, the cladding material of the fuel subassembly will be the 15-15 Ti work-hardened austenitic steel AIM1.

This is the most advanced grade of this type of material. The use of this material will necessarily limit the burn-up fraction of the core. Switching to a ferritic or martensitic ODS type material grade will be performed gradually.

Orientations

R&D on the AIM1 cladding must be finalised in priority, since this material will be the fuel cladding material for the first cores of Astrid. At present, R&D on AIM1 is based on post-irradiation examinations of 15-15Ti austenitic steels and advanced grades (Supernova and Oliphant experiments performed in Phenix). After introduction into Astrid, a performance enhancement strategy will be performed by continuing the adaptations of material grades (AIM2), with qualification of ODS type materials as a target in fine.

As regards ODS cladding, a development programme was defined in 2007 and has been implemented for several years in the fields of manufacturing, weldability and mechanical behaviour, among others. In 2009, ODS tubes were manufactured in CEA for the first time. The programme is aimed at defining a reference grade for ODS steels in 2015 approximately.

SiCSiC materials, and vanadium to a smaller extent, are also considered as they provide additional margins in terms of resistance to temperature. R&D work is in progress to determine their feasibility.

6.1.3. FUEL ELEMENT

The fuel element is composed of a steel pin which contains the fuel in the form of annular pellets.

In comparison with the former Phenix, Superphenix or EFR designs, the diameter of the pins of the new concepts is bigger (see Figure 6.1) with outside diameter values of approximately 9 to 10 mm (to be compared with 8.5 mm for Superphenix).

The diameter of the helical wire wound around the fuel pins to separate them and make the passage of sodium between the pins easier, is reduced to 1 mm. This choice of a small wire diameter associated with bigger pin diameters will increase the proportion of fuel and reduce the quantity of sodium inside the system, which is favourable for the target safety objectives.



A pin may contain a homogeneous fuel (U, Pu)O₂, or an axial heterogeneous fuel composed of UO₂ fertile columns and (U, Pu)O₂ fissile columns (see Figure 6.2).

Significant experience feedback is available for the homogeneous fuel pin with austenitic steel cladding, based on specifications validated by the Phenix experience feedback, many irradiations of subassemblies having a geometry similar to that of Superphenix and on the experience feedback of the manufacturing of Superphenix.

The axial heterogeneous fuel pin is based on experiments carried out in Rapsodie and Phenix, up to significant scales in terms of industrial manufacturing (approximately ten subassemblies of 217 pins). The current knowledge concerning the behaviour in irradiation in normal operating conditions is considered satisfactory, generally speaking.

Orientations

Based on the lessons learned with the specific irradiation experiments performed in Phenix (mainly the Zebre experiment), we may say that the CFV fuel heterogeneous concept is validated as regards its technological feasibility and its performance.

Additional qualification is expected with the examination of the CZAR and Pavix irradiations also carried out in Phenix.

Additionally, a prototype qualification irradiation programme, at the scale of a pin and a pin bundle, is under study to carry out such an irradiation in the Russian BN-600 reactor.

6.1.4. CORE AND SUBASSEMBLIES

The CFV core (core with low void effect), as presented in Chapter 3, is selected as the reference concept for the next part of the Astrid studies (see Figure 6.3).

This concept is based on an axial heterogeneous fuel and it includes a sodium plenum at the top part of the subassemblies. These options give to this concept the specific feature of a negative reactivity coefficient in case of draining, and they make this concept very favourable as regards loss-of-flow accidents. The core reactivity drop remains low in comparison with the Superphenix or EFR type cores, in particular thanks to the use of large-diameter fuel pins.

Characteristics of the CFV core

The main characteristic values of the CFV core, version 600 MWe and 1,500 MWe, are indicated in Table 6.1, with a comparison with the data of the EFR core. It is to be mentioned that the values for the CFV 600 and 1,500 MWe cores are very preliminary and not optimised at this stage of the studies.

FIGURE 6.2: SFR FUEL PINS

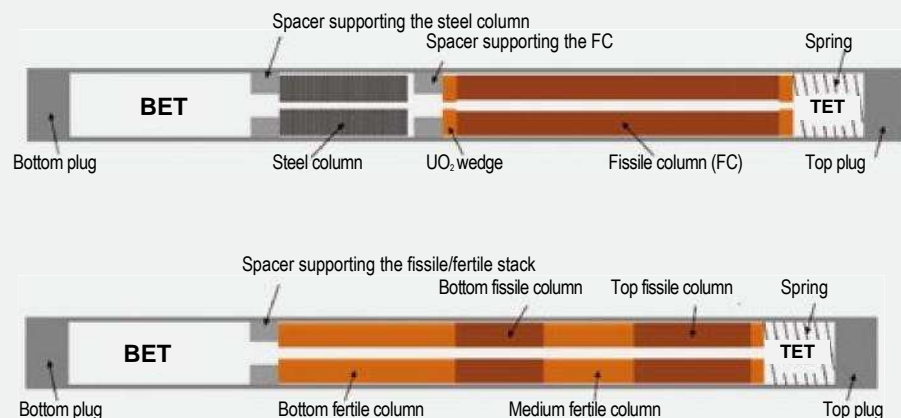

BET, TET = Bottom and top expansion tanks to recover the gas fission products generated during the irradiation.

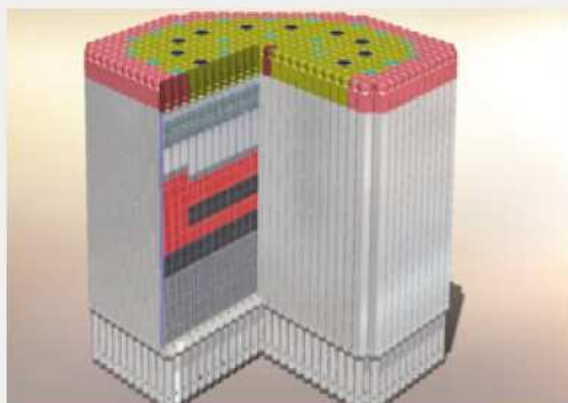
FIGURE 6.3: OVERALL VIEW OF THE CFV CORE

Performance

In comparison with a conventional EFR type core concept, the main improvements in terms of performance are as follows:

- possibility to significantly increase the cycle duration, thanks to the low loss of reactivity of the core (this loss is reduced by a factor of 2 in comparison with a conventional EFR type core), also favourable in terms of safety in case of “Control Rod withdrawal” accidents,
- negative reactivity effect in case of complete sodium draining (-1\$) to be compared with the +7\$ of EFR.

On the other hand, the power density of the CFV core is lower than that of an EFR type core. The in-core plutonium inventory is increased by approximately 30% and the overall diameter of the fissile core is bigger.

Safety of the CFV core

The parameters related to safety show a very significant improvement in comparison with a conventional homogeneous core, with mainly a very low or even negative draining effect, when this effect is highly positive (approximately +7\$) for an EFR type core.

The first assessments of accident situations performed on a CFV core show that, for local accident transients such as unexpected control rod withdrawal, the CFV core has a favourable behaviour thanks to the small reactivity reserve of the core. This potential still remains to be optimised by integrating the progress expected on detection systems.

For overall accident transients at the scale of the core, the natural behaviour of the core is dramatically different. The reference scenario for the study of a cooling failure likely to lead to complete core meltdown is a situation of loss of all the electrical systems of the reactor (ULOSSP: Unprotected Loss Of Station Supply Power), made worse by the absence of control rod drop. For the reactor, this leads to a loss of the forced convection in the primary system and the secondary system due to shutdown of the pumps, without tripping of the emergency shutdown and without starting of the ultimate safeguard systems.

TABLE 6.1: MAIN CHARACTERISTIC VALUES OF THE CFV CORE, VERSION 600 MWe AND 1,500 MWe (VERSION V0)

	CFV (ASTRID)	CFV (system)	EFR
Thermal power (MW)	1,500	3,600	3,600
Electrical power (MW)	600	1,500	1,500
Power density W/cm ²	228	230	303
Loss of reactivity per equivalent full power day (parts per hundred thousand)	-4.2	-3.0	-7.4
Overall draining effect (\$ ¹¹)	-0.5	-0.5	+7.0
Breeding gain (without radial breeder blankets for the CFV, and with radial breeder blankets for EFR)	-0.05	+0.02	- 0
Pu weight (metric tonnes)	5.1	12	9.5
Fissile radius (cm)	170	250	202

During this type of accident sequence, the negative draining reactivity effect of the core brings antireactivity to the system when the sodium temperature increases (unlike what happens in conventional cores), which is favourable to reduce the power of the reactor. Studies are in progress to accurately assess the improvements introduced by this favourable behaviour in all stages of the transient situation.

Orientations

The very favourable potential of the CFV core as regards loss of coolant accidents still remains to be confirmed in order to integrate the uncertainties associated with the calculations and to define the strategy as regards a possible additional shutdown system.

The neutron, thermal-hydraulic and mechanical studies made it possible, in autumn 2012, to define the orientations for an optimisation of the CFV core during the AVP2 phase. The target is to obtain a very high prevention level, relying as far as possible on the intrinsic characteristics of the core, since loss of coolant scenarios which initiate accidents will lead to complete core meltdown. This change of reference, which is a significant change with respect to what was done formerly on Superphenix and EFR, is a major progress.

¹¹ – The number of delayed neutrons produced by the natural disintegration of certain fission products (they are called “delayed” since they arrive with some delay with respect to the prompt neutrons directly produced by fission) by neutrons produced by fission is called “beta effective”. The value of this beta effective depends on the fissile nuclei present in the core. This value has a significant effect in the kinetic behaviour of the reactor. Injection of reactivity above the beta effective will lead to very fast runaway of the core. This parameter is so important that the Anglo-Saxons proposed to select it as a unit for kinetic studies. It is noted as \$ (dollar).

6.2. NUCLEAR ISLAND

6.2.1. PRINCIPLE OF “CLEAN” PRIMARY SYSTEM

The purpose of this principle is to prevent operation with burst open fuel clads, that is to say shut down the reactor as soon as clad failures are detected and place the subassembly in the periphery of the core before the evolution of the crack causes a release of fuel into the primary system. This prevents the contamination of the primary system with alpha emitters. This principle has always been applied in French reactors, due to the choice of the oxide fuel which chemically reacts with sodium; however this has not always been applied throughout the world when other choices of fuel were available (metal fuel).

With the objective of reaching the 4th generation criteria, it has been decided for Astrid not to change this principle of integrity of the first barrier.

The interest of this principle is to:

- use the advantage of SFRs, as they have a very low dosimetry and release a smaller quantity of effluents and waste,
- make maintenance, in-service inspection and repair operations easier,
- make dismantling easier.

6.2.2. POOL TYPE PRIMARY SYSTEM

The previous experience shows that the two concepts of loop or pool reactors have been widely studied, constructed and operated throughout the world.

One may notice a significant trend: small-size reactors are mainly loop-type whereas large-size reactors tend to be pool-type. The only significant exception is the JSFR project in Japan. Each solution has been analysed in detail in order to determine its advantages and drawbacks, and the pool concept is much better mastered in France for power reactors. Fundamentally, the pool concept has intrinsic advantages which give it the potential to comply with the safety criteria (high thermal inertia, guarantee of the inventory in primary sodium) when the loop-type concept reaches limitations (gas carryover, difficult natural convection, failure of primary system piping, etc.).

The experience feedback from the Fukushima accident reinforces this analysis even further: for safety reasons, the pool type primary system is therefore the system selected for Astrid.

6.2.3. PRESENCE OF AN INTERMEDIATE CIRCUIT

Several studies have been carried out to remove the intermediate circuit and reduce the cost of the power plant.

However, this option involves a significant obstacle: the primary system would then be separated from the power conversion fluid by only one heat exchanging wall. The power conversion fluid (gas or water-steam) has a high pressure, and in case of leakage it may massively enter the primary system and generate a reactivity accident possibly combined with a chemical accident in the case of water-steam.

Furthermore, for the water-steam systems, the sodium-water reactions would occur with radioactive sodium and this would lead to a radiological hazard combined with a chemical risk, with furthermore the risk of a significant quantity of gas entering the core. Although the concept of double wall tube steam generator can limit these risks, it does not preclude them completely in a robust safety demonstration.

Therefore, an intermediate system will be used in Astrid.

In order to eliminate the risk of sodium-water reaction, several fluids have been studied to replace sodium in the intermediate circuit.

However, none of the fluids considered has fully satisfactory characteristics as regards the main required criteria:

- compatibility with the primary sodium: this compatibility is fundamental. Any possibility of formation of solid compounds (which is the case, for instance, with PbBi) generates an additional difficulty in the safety demonstration (risks of blockage, in particular) which is hardly compatible with the requirement level prescribed for the 4th generation, not to forget the unavailability issues in case of contamination of the primary system,
- compatibility with the water-steam or the gas of the power conversion tertiary system,
- good resistance to high temperatures,
- absence of corrosion.

Therefore, sodium will remain the coolant for the intermediate system.

6.2.4. INTERNAL ARCHITECTURE OF THE MAIN VESSEL

The studies focused on a review of the design options of the internal vessel, with the following objectives:

- simplify the design to make construction easier and try to cut down on investments,
- improve the accessibility of internal structures for inspection and repair, and improve handling of subassemblies and large components,
- improve the robustness of the safety demonstration, in particular by improving natural convection, preventing the risk of gas entrainment from the free surface to the core, and by improving the resistance of the primary containment to a release of mechanical energy in case of damage of the core,
- make demonstration easier as regards the design of a reactor likely to operate up to 60 years.

The feasibility of four architectures (see Figure 6.4) has been assessed from the technological point of view, but also in terms of potential gains with respect to the previous criteria.

- **An architecture with conical inner vessel (redan)**, which takes advantage of the studies carried out for Phenix, Superphenix and EFR. This architecture is the most mature and simplifies the design with respect to what was made on Superphenix.

■ **An architecture with cylindrical internal vessel surrounded by the components**, called “CICI”, with the following objectives:

- simplification of the internal vessel and, as a consequence, improvement of the accessibility to structures in the hot and cold collectors,
- improvement of the robustness of the safety demonstration, in particular as regards the following points:
 - 1) possible improvement of the reliability of the decay heat removal (DHR) function; since the DHR systems are located in the cold pool, they are less exposed to high temperatures, they are protected against accident situations by the internal

vessel in case of release of mechanical energy, and finally they can provide a long-term cooling function and improve the reliability of the cooling function of the core catcher (if the core catcher is located inside the main vessel),

- 2) reduction of the risks of the gas entrainment from the free surface,
- 3) protection of the core supporting structures which are directly cooled when the DHR exchangers are in-operation.

This architecture is promising in terms of safety, but it involves technological difficulties, in particular the connection between the internal vessel and the intermediate exchanger.

FIGURE 6.4: MAIN INNOVATIVE ARCHITECTURES STUDIED

Architecture with internal vessel with conical inner vessel (redan)

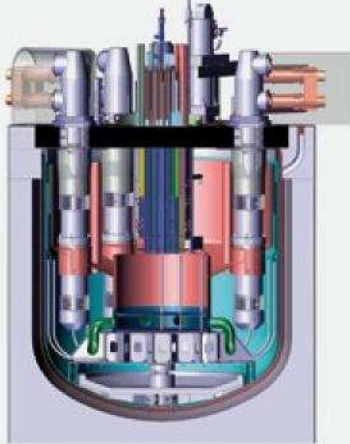

Architecture with cylindrical internal vessel surrounded by the components (CICI)

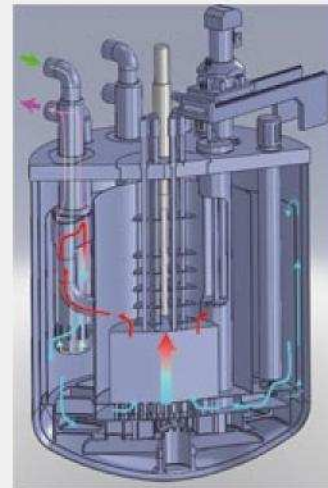

Architecture with stratified barrier (redan)

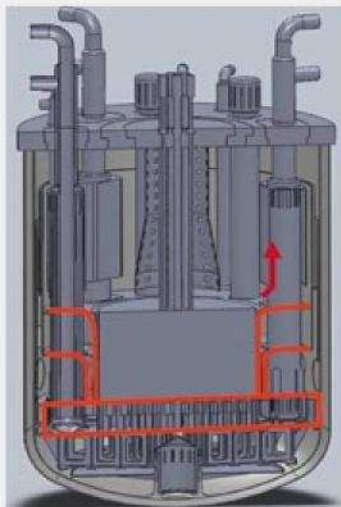

Architecture with cylindrical internal vessel containing the components (CICE) (Areva NP)

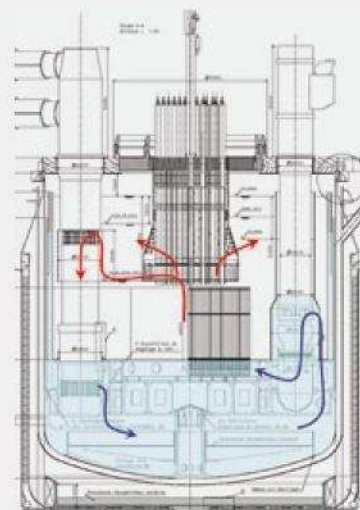

- **An architecture with cylindrical internal vessel containing the components**, called “CICE”, with the following objectives:
 - improved accessibility to internals above the supporting structure, thus improving inspection and repair operations,
 - simplified inner vessel,
 - possibility to install a large-capacity internal core catcher.

This architecture implies that the components are mainly located inside the hot pool, and it is based on the feasibility of a penetrating core supporting structure which separates the hot pool and the cold pool, which has very large dimensions with specific thermomechanical loads. The feasibility of this structure is the key element for this architecture.

- **An architecture “with stratified redan”** characterised by a thermal barrier (and not a physical barrier) obtained by stratification of the sodium between the 2 pools. This stratification is performed by a buffer area delimited by 2 redan type internal screens, thus allowing natural free circulation of the hot sodium towards the cold sodium, and therefore improving the implementation of a natural convection operation. Given that these screens do not need to be sealed, arrangements can be easily implemented to make ISIR easier. This innovation is very different from the other architectures and it requires some specific problems to be solved in order to reach a sufficient maturity level. These problems are related to the physical link between the outlets of the intermediate exchangers and the primary pumps, to the needs for regulation between the operating points of these two components and to the handling of pumps. Long-term R&D will be required to solve these issues.

Finally, the basic choice for Astrid fell on an internal vessel with simple inner vessel (redan) with conical shape.

In comparison with Superphenix, which was equipped with 2 internal vessels (one conical and one circular), this design allows significant simplification and weight saving (steel) and therefore cost saving.

Furthermore, sealing at the penetration of the intermediate exchangers is no longer achieved with an argon chamber but using friction metal contacts. This system significantly reduces the risk of gas bubbles from entering the core.

6.2.5. CORE SUPPORTING STRUCTURES

The core supporting structure must in no case suffer distortion, this in order to prevent core meltdown accidents. The principles which were applied to the design of the core supporting structure are robustness (through significant dimensioning margins and design redundancies) but also the integration of the inspection of these structures as from design.

Special care was also taken to simplify this structure and its manufacturability in order to reduce its weight and costs.

The design of the core supporting structures provides for in-

service inspection of this structure through suitable features, such as locating the welds in areas accessible from above the reactor, or installing guides to make the positioning of sensors and their carrying robot easier when necessary.

6.2.6. REACTOR BLOCK CLOSING SLAB

The design of the Superphenix slab (water-cooled mechanically welded structure) was abandoned for a slab composed of 2 gas-cooled forged plates (air or neutral gas cooling). The advantages are safety with the removal of water, and possibly lower cost through reduction of the reactor block’s height and diameter.

6.2.7. NEUTRON MONITORING

The core neutron monitoring system is conventional and comprised of two systems of absorber rods:

- the control rods, used to control the core, compensate for the burn-up of the fuel and for normal reactor shutdown,
- the shutdown rods which only have a safety function and which are used for reactor emergency shutdown.

Additionally, a third shutdown level is under study to make the shutdown system even more reliable. This level is based on a different operating principle to provide the system with increased diversification (Sepia system, see Chapter 3).

For the two conventional absorber rod systems, the control rod mechanisms have an essential safety function since they allow the control rods to be lowered inside the core to control the chain reaction.

To guarantee the reliability of this function, these systems are redundant and diversified and they are frequently tested, in particular at each criticality of the reactor.

The objective for Astrid is to review the designs of these mechanisms so as to simplify the design while guarantying a very high reliability and reduce the duration of periodical tests and therefore save a few hours, or even one or two days at each restart. The availability of the power plant will therefore be improved.

For that purpose, a value analysis action has been started and design studies are in progress among the engineering teams of the partners of the project.

6.2.8. MOLTEN CORE CATCHER

The core catcher is located below the core. It is an important component to guarantee containment in case of complete core meltdown accident; it has sufficient dimensions to recover all the corium. Today, three options are being studied within the scope of the AVPI phase: a core catcher located at the bottom of the main vessel (“internal” option), a core catcher located at the bottom of the safety vessel, therefore below the main vessel (“inter-vessel” option), and a core catcher located at the bottom of the reactor pit (“external” option), therefore below the main and safety vessels (see Chapter 3).

These three options comply with common requirements: good mechanical strength in normal operation and in case of accident, compatibility with sodium or gas in normal situation throughout the life of the power plant, compatibility with the sodium and the corium in case of severe accident, cooling and prevention of corium recriticality.

The selection of the core catcher option has not yet been made at this state of the studies.

6.2.9. DECAY HEAT REMOVAL

The advantage of sodium-cooled fast neutron reactors over pressurised water reactors is that they have a significant boiling margin in normal operation (more than 300°C) associated with a high thermal inertia and a non-pressurised primary system. However, this advantage does not remove the necessity to ensure the decay heat removal function (DHR) in all circumstances in the long run.

The design of Astrid is aimed at practically eliminating the situation of complete and prolonged loss of the DHR function, the demonstration of such elimination being based, in practice, both on a deterministic approach and a probabilistic analysis of the architecture.

Therefore, to achieve this objective, the decay heat removal systems are sufficiently redundant and diversified.

The first family of DHR systems (DHR DRC, for “Direct Reactor Cooling”) features an architecture which includes a Na/Na exchanger immersed in the main vessel, a Na/air exchanger and a final air cooling system (see Figure 6.5).

Two systems based on this architecture are under study: the first system works in natural convection mode, whereas the second system works in forced convection but still has significant natural

convention extraction capacities. Although these systems reuse some options already used in Phenix and Superphenix, several innovation possibilities are under study, such as the implementation of “long” exchangers running through the cold pool or the installation of DHR exchangers inside the current intermediate exchangers. Other innovations may concern the protection of the cold source and the robustness of the electrical power supplies.

The design of the second family (DHR TMV, for “Through the main vessel”) is aimed at removing the residual heat through the vessel and providing diversification with respect to the systems which penetrate through the slab of the reactor. This system is also intended to cool the corium located in the core catcher after a severe accident.

For these DHR systems, special attention is given to the experience feedback from the Fukushima accident as regards the autonomy of systems in case of loss of the electrical power supplies, so that these systems can be controlled in all circumstances. The DHR function is also protected against external hazards such as aircraft crashes, floods or earthquake.

6.2.10. INTERMEDIATE SODIUM LOOPS

Concerning the intermediate loops and the number of heat exchange components (primary and secondary pumps, intermediate exchangers), the objective is mainly economical. A minimum number of pumps is certainly required to fulfil the safety functions, but beyond this the major criterion is the cost of the components and systems, as well as their impact on the architecture of the power plant.

FIGURE 6.5: DECAY HEAT REMOVAL SYSTEMS DHR DRC (Na/Na EXCHANGER IN THE VESSEL) AND DHR TMV (FLOW THROUGH THE VESSEL)

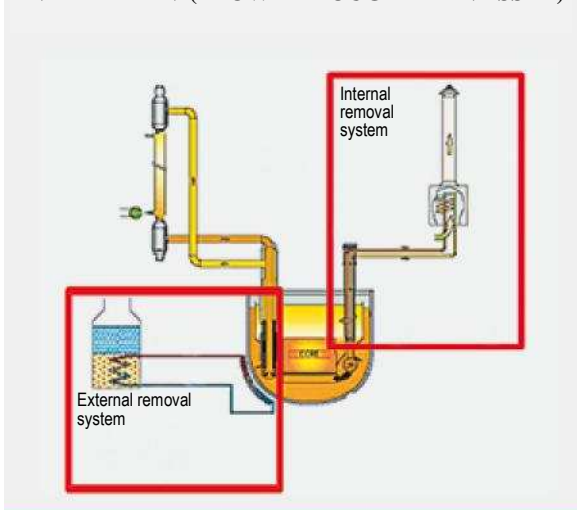
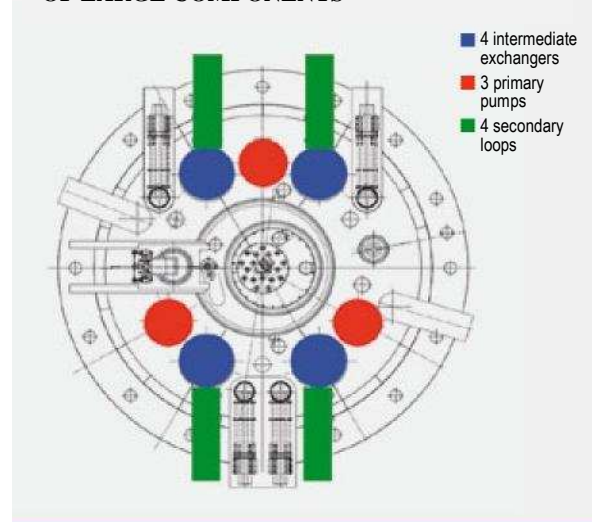

FIGURE 6.6: SELECTION AND LOCATION OF LARGE COMPONENTS





For all these reasons, and after study of various options, the selected solution includes 3 primary pumps, 4 intermediate exchangers and 4 secondary systems, each with a secondary pump.

This solution is best suited to the general layout of the power plant and to the separation between sodium areas and other areas. Finally, this is also the most economical one (see Figure 6.6).

To improve natural convection in the secondary system, high-power electromagnetic pumps are being developed, not to mention the expected advantages with this type of technology in terms of reliability, maintainability and minimisation of auxiliary systems. The studies carried out led to the conclusion that it is necessary to orient the studies towards the development of electromagnetic pumps with “passive” cooling by the sodium of the secondary loop, therefore without specific cooling system, which removes possible sources of incident. This requires to develop dual stator electromagnetic pumps with coiling able to withstand high temperatures. An R&D programme which combines an experimental part and modelling work has been initiated in order to better comprehend the electromagnetic instabilities found during transient phases.

6.3. POWER CONVERSION SYSTEM

The chemical reaction between large quantities of sodium and water is a significant risk, since such a reaction is highly exothermic and produces soda which is corrosive for the structures and hydrogen which might explode. Steam generators are the components in which the risk of sodium-water reaction is at its highest level, since these the 2 liquids are only separated by a thin metal wall and these heat exchanging components are exposed to high mechanical and thermal stresses.

In the past, this phenomenon was well kept under control by means of high-performance detection and protection systems: the small number of sodium-water reactions which occurred on the Phenix reactor were detected very early, much before they could reach a hazardous level.

However, with a view to further improve safety (and also the availability of the facility, since a sodium-water reaction will lead to reactor shutdown), the objective will be either to fully eliminate the possibility of a sodium-water reaction at the heat exchangers by using an alternative fluid (replacement of water with gas), or guarantee the absence of consequences on safety even if a major sodium-water reaction occurred despite the redundancy of the detection and protection systems.

The descriptions of the power conversion systems, whether these are gas systems (Brayton cycle) or water systems (Rankine cycle), currently under study, are presented in Chapter 3.

The choice proposed for Astrid will be made in February 2013. Given the strong attractiveness of this concept which completely eliminates the risk of sodium-water reaction and given the fact that there is no redhibitory point, the current trend is to select a gas power conversion system as the reference option.

6.4. HANDLING OF FUEL SUBASSEMBLIES

The stakes and general principles of fuel subassembly handling are detailed in Chapter 3.

The number and type of subassemblies to be handled vary depending on the size and the concept of the reactor, the core reloading strategy or the safety options.

The fuel replacement operations are carried out with a shutdown reactor, with sodium temperatures which may vary between 180 and 250°C depending on the situations. These operations are preceded and followed by, respectively, FON-MANU operations (transition from the reactor operating state to the handling state) and MANU-FON operations (transition from the handling state to the reactor operating state). These operations have a significant impact on the reactor unavailability period.

Furthermore, a few constraints have to be taken into account for the design of the handling means, such as the residual heat of the fuel subassemblies for their transfer and cleaning, the complete unloading of the core, or also the management of fuel subassemblies containing minor actinides.

As a consequence, there are many options which can be considered to face the handling functions and constraints, and the option selection is imposed by technical criteria (geometry of the core, type of fuel subassemblies, residual power, impact of the reactor block, etc.), economic criteria (investment and operating costs, reactor availability factor) and safety criteria (complete core unloading, inspection of structures, evacuation and reprocessing channels, etc.).

The paragraphs below illustrate the progress of the technical studies.

6.4.1. IN-VESSEL HANDLING

6.4.1.1. INSTALLATION OF NEW SUBASSEMBLIES IN THE CORE AND REMOVAL OF IRRADIATED SUBASSEMBLIES

The basic option selected for in-vessel fuel handling for Astrid is handling under dual rotating plug with a transfer arm on the large rotating plug and a transfer beam on the small rotating plug - see Figure 6.7.

The rotation of the plugs, associated with the rotation of the fixed-shift arm, allows all the subassemblies to be handled.

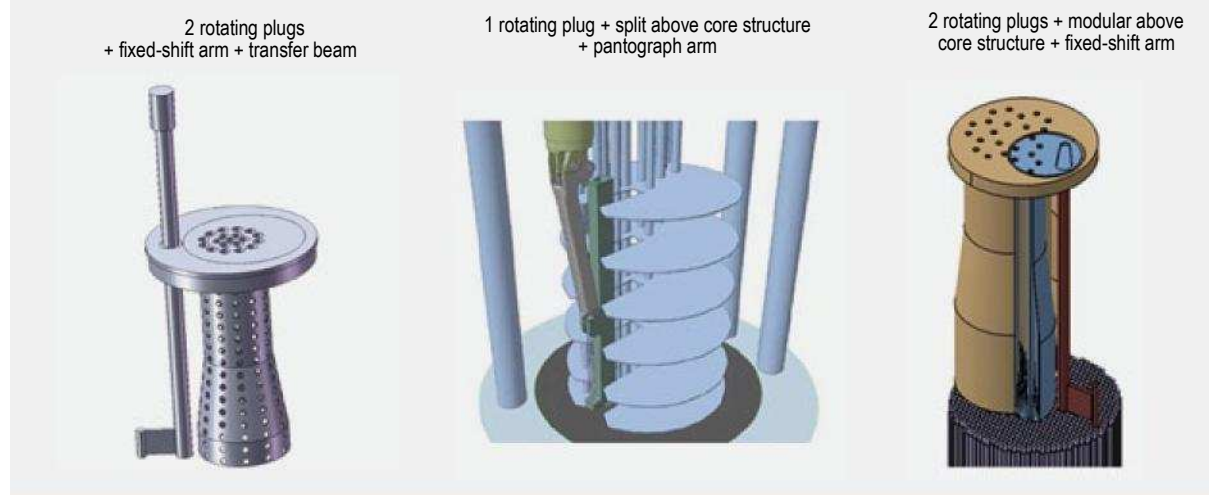
FIGURE 6.7: SOLUTIONS STUDIED FOR IN-VESSEL HANDLING

At this stage of the studies, this is the most robust solution (simple lifting machines and significant experience feedback) and therefore there should be no obstacles related to technologies or component design.

The solutions with pantograph arm and split above core structure or two-part above core structure avoid the need for recovery operations and may allow a reduction of the diameter of the rotating plugs. However, these solutions are not selected for the studies of the AVPI phase. As a matter of fact, in addition to the difficulties to design and define the thermomechanical characteristics of these complex above core structures, these concepts have significant flaws in terms of safety: monitoring of subassemblies located below the split areas, resistance to earthquakes, management of the situations of jammed arm in the above core structure.

6.4.1.2. REARRANGEMENT OF THE CORE

Several systems for in-vessel swapping between Irradiated Subassemblies and New Subassemblies (IS/NS) are under study:

- Swapping in buffer areas, in reserved places within the lateral neutron shielding, in order to swap between a used assembly and a new assembly. The buffer areas may just be props able to temporarily receive one assembly. This simple principle requires few investments. However, the increasing number of assembly recovery operations and rotating plug turning operations necessary for IS/NS swapping significantly reduces the handling speeds and leads to a significant risk of reduction of the reliability of the system (impact on availability and safety).
- Swapping using a dual-space handling container allowing either a new assembly or an irradiated assembly to be positioned and transported in one single dual-space container. The dual-space container optimises the handling speeds and removes the needs to connect and disconnect the container. However, this solution has drawbacks such as an increase in the dimensions of the slab penetrations and the equipment of the handling systems, and a higher risk of handling mistake due to the fact that the IS/NS spaces in the container are close to each other.

The next studies concerning the design of the IS/NS swapping options and the handling machines will provide further information as regards the handling speed criteria, the costs, the operability and safety, and they will allow a decision to be made as to the option selection concerning this component.

6.4.2. LOADING / UNLOADING SYSTEM

The design options for the fuel subassembly loading/unloading system of the Astrid reactor are based on cask and ramp systems (see Figure 6.8).

With the cask system, the cask is positioned above the slab to remove or install a subassembly. Sealing is ensured by means of a valve system, one valve for the cask and one for the slab. Therefore, there is no handling component permanently installed on the slab, except the valve.

The system with dual ramp and chamber is a well-proven system based on significant experience feedback (Phenix, Superphenix). The chamber which allows the sodium handling container to be transferred from one ramp to the other can be equipped with a rocker or a turnstile.

Mixed solutions are also considered, which combine ramps and casks or transfer corridors.

The cask with sodium container is an innovative system which does not require load pick-up and which allows better flexibility for the downstream handling system, and it can be easily pooled. However, the cask and its biological protection are big and heavy components which require the displacement of heavy loads, in particular on the reactor slab. Therefore, one of the major drawbacks of a cask system is the significant constraints imposed on civil engineering works (large dimension opening which reduces the pressure resistance of the reactor building) and on operability (requalification of the containment of the reactor building after opening). From a technological standpoint, the obstacles lie in the qualification of the thermal capacity of the cask and mechanical devices (valves, grabbing, recovery of sodium droplets).

FIGURE 6.8: SOLUTIONS STUDIED FOR LOADING / UNLOADING

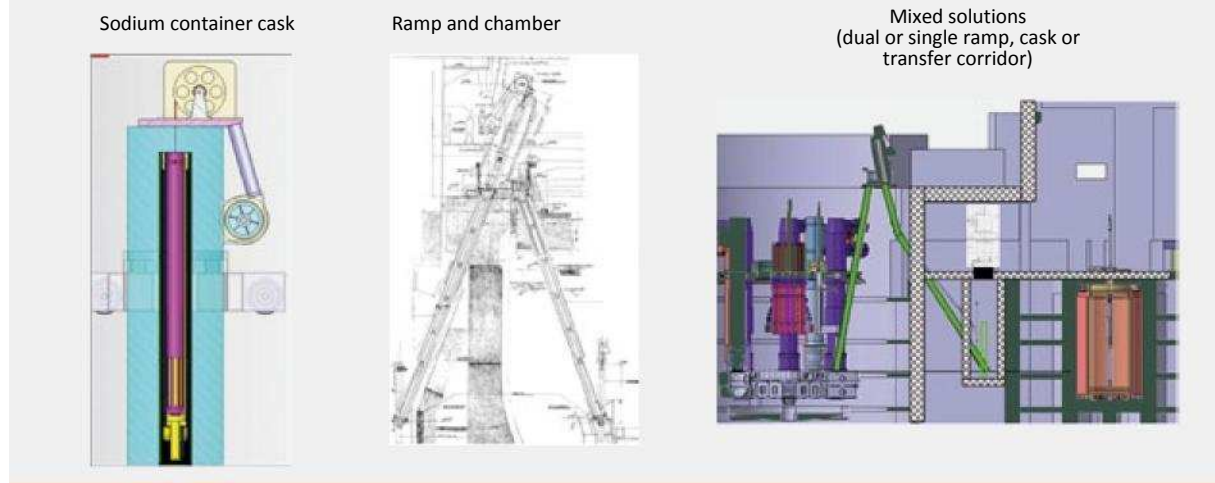

This cask system is maintained as an option for its potential in case of use for the future commercial reactors. In particular efforts will focus on its impact on the general facility and the civil engineering works, as well as on the consequences in terms of operability and availability (performance in terms of handling speed).

The dual ramp and chamber system is a mature solution which has good performance in terms of handling speed and which does not require load pick-up or handling of heavy components. However, it requires ex-vessel handling systems to be located nearby, in particular for external storage, and therefore this becomes a major drawback for the extrapolation to the future commercial reactors with the objective of pooling the handling means for two twin power units located on the same site. This solution is kept as a possible backup solution for the AVP2 phase.

The general principle of the mixed solutions is based on a concept of single or dual ramp to remove the subassemblies from the reactor block, then the system for transfer to the external storage area by means of a cask or a handling corridor. The mixed solution is very interesting since it takes advantage from both concepts: the ramp allows the fuel subassembly to be removed from the containment of the reactor building without the need to create a particular opening in the containment, while handling in cask or corridor allows pooling the equipment within a sector. An option of mixed solution with gas transfer corridor, stemming from the search for innovative solutions, has been studied in detail and has formed the subject of an installation study.

The selection of the reference loading/unloading concept between the sodium container solution and the mixed solution will be made in the first quarter of 2013, based on the expected additional information concerning the containment options for Astrid.

6.4.3. EX-VESSEL HANDLING

Different technical solutions are under study for each point related to ex-vessel handling. The objective of the work programme in the AVP2 phase is to confirm the technical feasibility of these options in order to define the general architecture of this handling system.

As regards the cleaning processes, the studies in progress on innovative systems will be continued during the AVP2. They are aimed at simplifying the current reference process (water spraying in carbon dioxide) while simultaneously improving safety and allowing an increase in the cleaning speed.

6.5. IN-SERVICE INSTRUMENTATION AND INSPECTION (ISIR)

6.5.1. CONTEXT AND APPROACH

Instrumentation, in-service inspection and repair, gathered under the notion of ISIR, are important elements of the Astrid project. As a matter of fact, the opacity and reactivity of sodium make these activities much more difficult than in a water reactor.

In the past, the French Nuclear Safety Authority pointed out that the difficulty to carry out the periodical inspection of the internal structures of the primary system was a weak point of the sector which had to be absolutely solved.

Significant progress had certainly been made on the Phenix reactor by the time its safety was re-assessed in 1999-2000 and at the time of the examinations which were performed on the reactor, but this issue remains a major stake. This is why this field is studied as from the beginning of the conceptual design phase, so that the instrumentation and the inspection and repair means are available on time to allow the starting and operation of the Astrid reactor.

The developments currently in progress on ISIR concern 5 levels:

- Level 0 – integration of ISIR in the design,
- Level 1 – continuous monitoring, with the reactor in operation (instrumentation),
- Level 2 – periodical inspections, during scheduled reactor outage periods,
- Level 3 – exceptional inspections, with reactor shut down,
- Level 4 – repairs / replacements, safeguarding of investment / availability.

Level 0 was added to the 4 levels usually considered, since taking the ISIR objectives into account as from the design phase allows the main part of the problem to be solved.

For the purposes of the project, the studies concern complete measuring systems including, for the magnitude to be measured:

- the technology selected for the measurement,
- the sensor/probe itself,
- the position of the sensor/probe with respect to the magnitude to be measured (carrier, for instance),
- the means used to bring the sensor/probe at the desired place,
- signal transfer,
- signal processing,
- data processing for the operator.

This field covers all the existing measurements in a nuclear power plant, but it is obvious that the primary system, with the presence of sodium, involves the highest constraints in terms of safety and difficulty. This field is covered by many engineering studies and research programmes, but above all by development programmes with CEA R&D and with the partners (Areva, EDF and Comex Nucléaire).

Today, one or more solutions have been identified to meet each one of these requirements. This means dozens of developments which cannot be summarised here. Only a few significant examples will be described in the remaining part of this document.

6.5.2. IN-SERVICE MONITORING

6.5.2.1. CHALLENGES OF IN-SERVICE MONITORING

In terms of continuous monitoring, the technologies used in the Phenix and Superphenix reactors gave satisfactory results. However, for Astrid, the following appears necessary:

- Meet much higher safety requirements than before, in order to reduce the probability of a severe accident and simultaneously take this severe accident into account to reduce its consequences. In certain cases, this requires further redundancy or diversification, and the detection of situations not taken into account in the past. The example of the detection of fuel subassembly blockage phenomena will be described further.
- The Fukushima accident demonstrated that it has become necessary to develop a post-accident instrumentation to manage the consequences of a severe accident over time. At the same time, we are studying the operating limits of conventional instrumentation (for example, a thermocouple or an optical fibre can withstand temperatures above 1,000°C) and the resistance of this instrumentation to accidents. Furthermore, we are analysing the installation of

instrumentation dedicated to severe accidents which could be permanently installed or installed just after the accident.

- Search for modern technologies; as a matter of fact, the instrumentation of the Phenix and Superphenix reactors was designed more than 30 years ago and, since then, the industry has made considerable progress in terms of technologies, miniaturisation and signal and data processing. It is therefore necessary to integrate this progress into the design of Astrid in order to improve its performance, reinforce its reliability, improve its availability, make its operation easier and reduce its costs.

6.5.2.2. EXAMPLES

Optical fibres (OF)

Fibre Bragg gratings are interesting, in particular because they allow several measurements to be performed with only one fibre (see Figure 6.9).

This property is particularly interesting to measure temperature profiles or to check temperatures over great lengths.

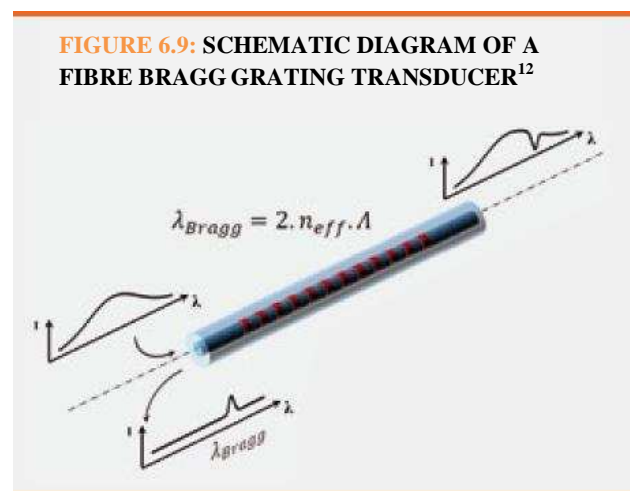

For a great length, only one optical fibre would be equivalent to many thermocouples, whereas it is necessary to install one thermocouple for each measurement point.

Furthermore, optical fibres can be used as leakage detectors on pipes.

As a matter of fact, the temperature rise or the deterioration of an optical fibre is a means to detect and locate a sodium leakage.

¹² – The refractive index of the glass used in the core of an optical fibre is structured to a scale of 500 nm by photo-writing in laser light, through the use of an interference pattern. The result is a diffraction grating in the core of an optical fibre, this grating being composed of several thousands of pitches on a few millimetres.

A wideband light source, usually operating in the range 1.55 μm, interrogates the Bragg grating which reflects a unique wave length, called "Bragg wavelength". The variations of this wavelength are directly related to the parameters to be measured, such as temperature and strain.

These transducers can be wavelength multiplexed and they make it possible to create a sensor grating along one or more optical fibres.

CEA has tested a stainless-steel-clad optical fibre in sodium, with very encouraging results (response time less than 300 ms). However, data concerning the service life of optical fibres at high temperatures is still insufficient and additional R&D is necessary.

For use in the primary system, the performance and resistance to irradiation still need to be improved.

With its small overall dimensions and its short response times, this measurement technique is of great interest in or out of sodium, but the data on performance and service life at high temperatures (and in irradiation) needs to be consolidated.

Therefore, it seems possible to use optical fibres in Astrid out of the primary system and inside the primary system, simultaneously with thermocouple measurements.

Detection of fuel subassembly blockage phenomena

Fuel subassembly blockage phenomena are local anomalies which are likely to worsen and lead to a complete core meltdown accident. This is why early detection is important. In the past, these phenomena were not detected before the fuel subassembly meltdown and the beginning of propagation to the adjacent subassemblies. Improving the robustness of the safety demonstration requires a reduction of the detection time.

Given the difficulty of this measurement, several technologies are studied at the same time (see Figure 6.10): neutron detection, neutron noise detection, temperature measurements, flowrate measurements, acoustic detection.

One of the main difficulties is to make sure that the uncertainties on these measurements are sufficiently low with respect to the expected variations and, above all, that the variations in case of blockage can be rapidly identified with respect to the normal variations which are due to the turbulent flow of the sodium in this area.

During the AVP2 phase, CEA will try to obtain significant results concerning flowrate measurement at subassembly outlet.

A system for processing all the data generated by the reactor measurement and monitoring system, with on-line signal processing, will have to allow cross comparison of this data. Therefore, this is probably a combination of these detection means, depending on their maturity level, which will be implemented on Astrid in order to make diagnosis reliable.

6.5.3. PERIODICAL INSPECTION

6.5.3.1. CHALLENGES OF PERIODICAL INSPECTION

For the Phenix and Superphenix reactors, prevention of the degradation of the internal core supporting structures was ensured by significant design margins as well as by a very strict manufacturing quality control. These requirements are still valid for Astrid but they are no longer sufficient, and the ASN (French Nuclear Safety Authority) now also requires that the structures and components important to safety can be periodically inspected.

The presence of sodium makes such an inspection difficult. This is why it is taken into account as from the conceptual design phase of Astrid in order to reduce its cost, and to reduce the operating constraints and the duration of the reactor shutdown periods.

Furthermore, this inspection shall make it possible to obtain data to substantiate the 60-year service life of the power plant.

FIGURE 6.10: EXAMPLES OF INSTRUMENTATIONS FOR THE DETECTION OF FUEL SUBASSEMBLY BLOCKAGE PHENOMENA

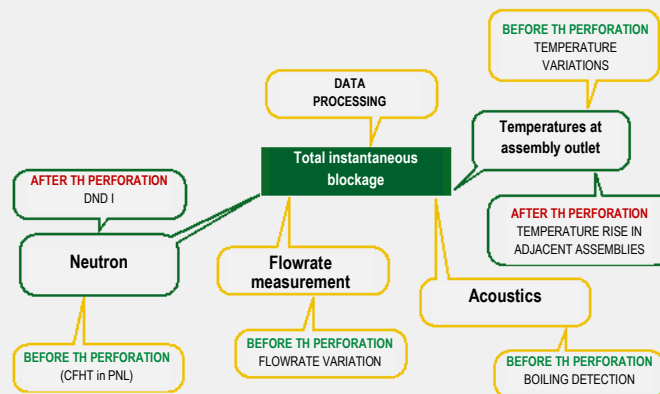

CFHT: High temperature fission chamber
DND i: Delayed neutron detection inside the vessel

TH: Hexagonal tube
PNL: Lateral neutron shielding

FIGURE 6.11: ULTRASONIC INSPECTION OF STRUCTURES

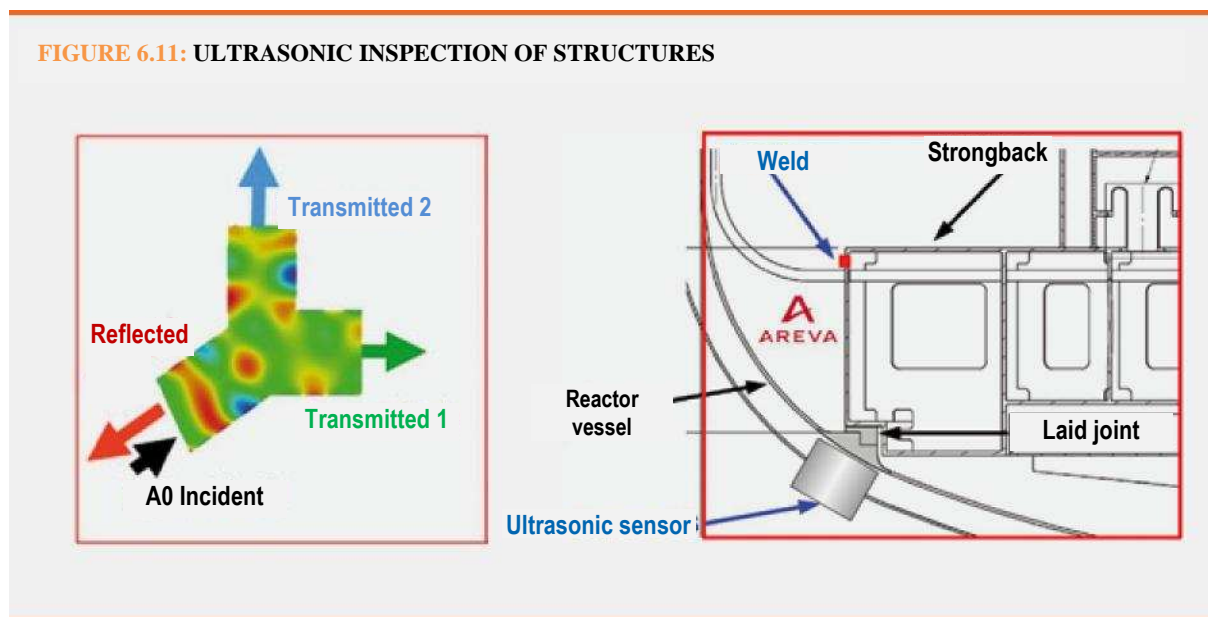

In addition to a design which makes access easier, the developments do not only concern the sensors but also the carriers and the signal processing system. All these components must be able to withstand the inspection conditions: temperature, radiation, presence of sodium or sodium aerosols.

When this is possible, inspection from the outside of the primary system shall be privileged, as it is easier than in sodium.

6.5.3.2. EXAMPLE OF INTERACTION BETWEEN THE DESIGN AND THE INSPECTION OF THE STRONGBACK

The strongback is the structure which supports the core. It is completely immersed in sodium and rests on the main vessel. It is both a structure very important to safety and one of the most difficult structures to inspect.

The possible inspections from the outside or the inside of the vessel are detailed below, as illustration examples.

Inspection from the outside of the vessel

This is the preferred technology for the inspection of the structure, since the sensor and the carrier remain in a gas environment.

This measurement technique uses ultrasounds (US) which propagate within the material to the welds and to the flaws, if any.

This method requires continuity in the transmission of the emission and reception signals.

Since one of the option selections concerns a strongback laid on the main vessel rather than welded to it, the impact on the quality of the inspections must be assessed. Therefore, the transmission of US through a laid joint (with hard coatings) and a welded joint will be experimentally tested in conditions which are similar to and representative of the constraints on the main vessel (see Figure 6.11). The result of these studies will contribute to the selection of one option or the other.

Inspection from inside the vessel

It is possible that inspection from the outside may not provide access to all the welds which are to be inspected.

This is why we are also developing an in-sodium inspection technology which would make it possible to reach the strongback through a space cleared by removing one fuel subassembly.

As the strongback is a box and rib structure, the crossing point is drilled to provide access for a sensor. The ribs are located below the bottom ends of the fuel subassemblies so that the carrier and the sensor can have direct access.

6.6. INSTRUMENTATION AND CONTROL

6.6.1. Context and approach

The architecture of the Astrid instrumentation and control system is governed by high-level safety and functional structuring requirements, in particular:

- the strategy of defence in depth (definition of levels and allocation of the safety functions within these levels),
- the requirements in terms of independence, geographical separation and diversity for the management of the common load failures,
- the safety classification of the instrumentation and control systems which perform these safety functions,
- the control/operating principles of the Astrid reactor,
- the strategy as regards maintenance,
- the requirements related to human and organisational factors.

For that purpose, these studies are carried out in close cooperation with the Areva and EDF partners. Therefore, we can take advantage of their significant experience feedback obtained, among others, on the EPR reactor and on the studies of the ATMEA reactor.

6.6.2. BASIC PRINCIPLES FOR THE DESIGN OF ASTRID'S INSTRUMENTATION AND CONTROL SYSTEM

The design principles for the instrumentation and control system must contribute to the safety and availability of the reactor. They will provide a good readability of its architecture, with the objective of increased robustness in the safety demonstration.

For all the operating situations of the reactor (control in normal and accident situations), the control of the Astrid reactor is centralised from the desks of the main control room and from the emergency shutdown panel should the main control room be unavailable. The handling operations will be controlled and monitored from a dedicated area in the main control room, or from an independent room with transmission of information to the main control room.

The design of Astrid's safety instrumentation and control system is based on a deterministic approach which relies on the principle of defence in depth. The instrumentation and control system which ensures the fourth level of defence in depth is the severe accident management system.

The instrumentation and control systems dedicated to the various levels of defence in depth are governed by rules of independence and geographical separation and, for the strong lines of defence, these systems are diversified and designed in accordance with the single failure criterion¹³.

A system which is a strong line of defence (i.e. the reactor emergency shutdown system or the decay heat removal (DHR) system) will have the highest safety classification and will be fully protected against internal hazards (fire, sodium aerosol), external hazards (resistance to earthquakes, lightning, etc.) or malicious acts.

6.6.3. ARCHITECTURE ELEMENTS FOR ASTRID'S INSTRUMENTATION AND CONTROL SYSTEM

The architecture of the instrumentation and control system of the Astrid reactor is based on the principle of breakdown into levels. These levels are detailed below:

- Level 0 "Process interface": this level includes electrical conditioning of sensor signals for the next higher level, management of priorities for the control orders coming from the next higher level and generation of the electrical commands to control the actuators.
- Level 1 "Acquisition, processing and automation": this level includes the electronic systems which perform the acquisition and processing functions necessary to obtain the measurements representative of the condition of the reactor and its associated systems. This level generates the electrical commands sent by the supervision system.
- Level 2 "Supervision": this level includes the centralised systems for the control of the reactor in normal, incident or accident situations.

¹³ – A system designed in accordance with the single failure criterion must have sufficient redundancy to allow the function to be performed, irrespective of the first failure mode. Isolating devices must be implemented to guarantee that the failures will not propagate.

- Level 3 "Performance and optimisation": this level stores the reactor control data. This data will be used for analysis in case of incident, for crisis management assistance and, in the long run, to optimise the performance of the reactor.

This architecture will also comply with the independence of the following functions:

- The "operational" instrumentation and control system will control the reactor in normal operating conditions. Usually this system has no safety class and it complies only with the overall availability requirement.
- The "safety" instrumentation and control system will perform the reactor emergency shutdown function as well as the protection and safeguard actions (e.g.: decay heat removal systems, containment control systems). These systems are classified at the highest level of safety requirements.
- The instrumentation and control system for severe accident management, which also performs functions related to post-accident control (lessons learned from the Fukushima accident).

6.6.4. POSSIBLE TECHNOLOGIES FOR THE INSTRUMENTATION AND CONTROL SYSTEM

The architecture of the safety instrumentation and control system may be based on Areva's TELEPERM XS digital instrumentation and control system. This electronic system has the highest safety level and it uses a microprocessor-based technology. It is designed to perform functions requiring a very fast reaction time and to comply with high reliability requirements. It takes advantage of the experience feedback from the safety instructions of the EPR reactors which are under construction.

Depending on the safety analyses, and when a diversification requirement is issued, the diversified safety system may use a non-programmable technology (analogue electronics, or digital electronics based on non-reprogrammable components).

6.6.5. PERSPECTIVES

Technological diversification based on ruggedized analogue, non-reprogrammable, digital or mixed electronics with a high level of integration is a significant area of improvement for the architecture of the instrumentation and control system of the Astrid reactor.

The objective is to have improved protection against common mode failures, malicious acts (programmed systems) or parameterisation or reprogramming errors, while minimising the volume occupied by these systems (wiring, number of cabinets).

Signal processing capabilities (grouping, threshold detection, alarms, algorithms) installed locally as close to the instrumentation system as possible are under consideration in order to reduce the volume of cable ways for remote data processing.



7.

ASSOCIATED FACILITIES FOR THE CYCLE OF ASTRID	61
7.1. Associated fuel cycle - Adaptation to the specific features of fast breeder reactors	61
7.2. Evolution of technologies.....	62
7.3. Fuel cycle workshops	63
7.3.1. Core manufacturing facility (AFC)	63
7.3.2. Used fuel processing facility (ATC)	64
7.3.3. Facility for the manufacturing of elements containing minor actinides	65

7.

ASSOCIATED FACILITIES FOR THE CYCLE OF ASTRID

7.1. ASSOCIATED FUEL CYCLE - ADAPTATION TO THE SPECIFIC FEATURES OF FAST BREEDER REACTORS

Figure 7.1 illustrates the material cycle within a fleet of isogenerating Fast Breeder Reactors (FBR). At equilibrium, only 50 metric tonnes of depleted uranium are necessary every year to feed a fleet of FBRs with 60 GWe of installed power.

To process the fuels allowing plutonium multi-recycling, two main phases are necessary:

- processing (with increased capacity) of the used MOX fuels from Light Water Reactors (LWR), to recover the plutonium necessary to manufacture the first cores of fast breeder reactors (FBR),
- processing of the used MOX fuels of these FBRs, such processing being materialised by multiple recycling of the plutonium, which is the main fissile material both consumed and produced within this type of reactors.

The first phase requires R&D for adaptation and/or optimisation of the processes, integrating in particular the management of high plutonium concentrations. The second phase requires more innovative R&D, based on the processing campaigns carried out previously on the Phenix reactor fuels in the pilot workshops of Marcoule and the industrial workshops of La Hague, and based on the first technological developments carried out between 1970 and 1990 in Marcoule (processing) and in Cadarache (manufacturing).

Whatever the deployment phase, a common characteristic to these two steps is that the fuels to be processed/recycled concentrate a larger quantity of fissile materials than the used UOX fuels. The plutonium content is higher, thereby amplifying the criticality management constraints and making the fuel less soluble in the current state of knowledge. Another specific feature of used FBR fuels is their concentration of fission products greater than that of UOX fuels (approximately 3 to 4 times higher), mainly due to higher burn-up fractions, with a wider spectrum of these elements, in particular significantly increased plutonoid contents (this is due to the specificity of the fission of plutonium in comparison to that of ^{235}U) whose management is difficult during processing (relatively refractory solid phases hardly miscible in conventional glass matrices). In the current state of the knowledge, this can lead to high fractions of undissolved solids at the beginning of the processing.

Considering the operating principle of the core, the design of FBR fuels requires a larger number of bigger structure elements outside the fissile material (blankets, expansion vessel, neutron shielding, end pieces, hexagonal tubes, etc.). As a result, these elements constitute a weight which is two to three times higher than that of the fuel pellets. In comparison, the weight of the structure elements of UOX fuels or MOX LWR fuels is fifty percent smaller than that of the oxide pellets contained. In the past (in particular for the used fuel of the Phenix reactor), solutions were developed to allow the used fuel to get access to the head-end of a processing/recycling process. Astrid will take advantage of these developments. In the long run, it will be necessary to develop optimised processes for a factory dedicated

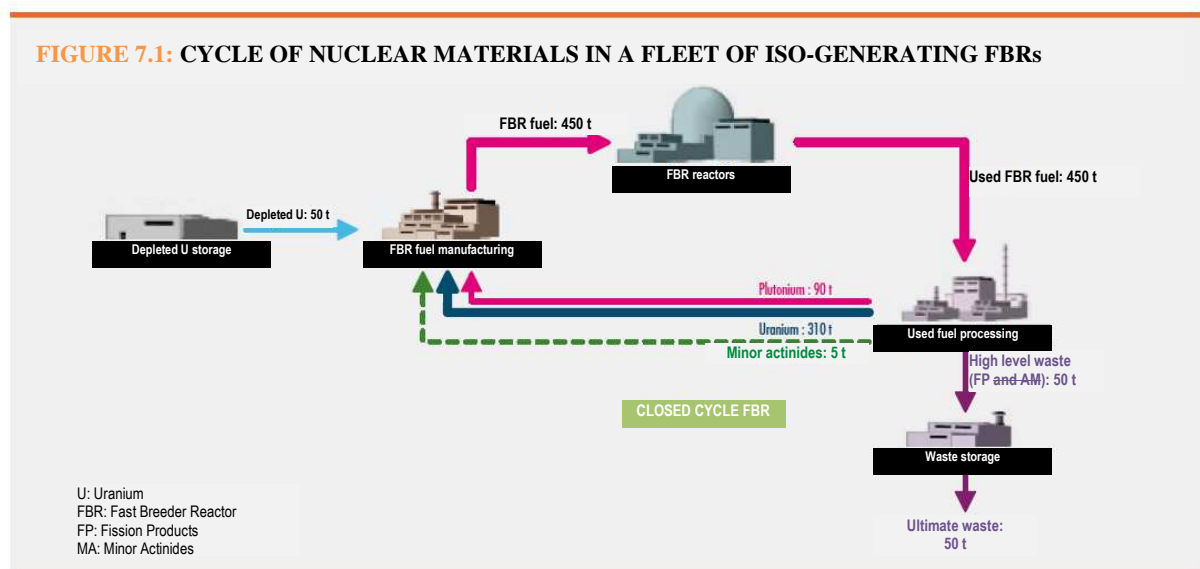



to the manufacturing of FBR fuel, that is to say capable of withstanding processing rates similar to those of the current generation. Ways of improvement will have to be studied in relation to the design of the subassembly, as regards the removal of the top and bottom ends of the subassembly, the opening of the hexagonal tube, the removal of the spacing wire, and the shearing mode. The search for solutions intended to limit the volume of high-level long-lived waste and medium-level long-lived waste will require innovative sorting, decontamination, concentration and containment concepts and it will be a motivation to develop associated processes and technologies.

Due to the high temperatures and the significant breakup of the fuel pellets in the core within the cladding, the FBR fuel leads to significant release of gas fission products within the cladding. Most of the gas is mainly released during shearing, which makes it possible to imagine a potentially simplified management of releases (no mixing with the NO_x from dissolution), or even a significant reduction of these releases by means of new, more direct and more compact trapping and conditioning or containment processes.

The selection of materials, in particular for cladding, brings new issues or requires former issues to be reconsidered, depending on the selection of the materials for this cladding. This point is to be taken into account in detail for the ODS steels (the presence of Cr or Fe must be avoided in the dissolution solutions).

To meet the objectives of the FBR cycle, fuel manufacturing must also achieve the significant objectives below:

- capability to recycle all qualities of plutonium and uranium which are available in the current and future fuel cycle. Therefore, the manufacturing plants must integrate the use of reprocessed plutonium from the UOX and MOX LWR fuels, and of course, the fuel produced by FBRs themselves,
- keep a high level of safety of nuclear facilities, and in particular limit the doses received by the operators to a level even lower than the level found in the current facilities,
- operate with excellent availability to ensure reliable feeding of reactors as needed,
- achieve acceptable economic performance through overall automation of the operations in glove boxes and through good production efficiency.

The variation of the isotope vector of plutonium, with the possibility of high contents of isotopes 238 and 241 (the latter forms americium 241 through decay) is a significant constraint which must be taken into account to achieve these objectives.

The experience acquired with the plutonium technology workshop (ATPu) in Cadarache and the continuous improvements implemented in Areva's MELOX factory which manufactures MOX fuels constitute a good basis to design the core manufacturing facility and reach these objectives.

Furthermore, the R&D programme, which has been in place within CEA for a few years in cooperation with Areva, proposes innovations to simplify the steps of the manufacturing process and in particular those steps which use powders. Therefore, the

purpose is to base the process on a single step of powder mixing (taking advantage, as applicable, of the future availability of new precursors such as powders produced with the COEXTM process), followed by forming and by an optimised nuclear ceramic densification cycle.

7.2. EVOLUTION OF TECHNOLOGIES

The specific features of the used FBR fuel described above lead us to identify subjects of interest to be studied within the scope of an R&D programme, with the objective of a significant part of optimisations and innovations applicable to current and future processing and recycling industrial processes:

- process head-end which integrates the dissolution of materials, in particular the production of plutonium solution with a high FBR specificity in this step,
- separation of reusable plutonium and uranium materials, with a material flow management to be adapted,
- conversion of plutonium and uranium into raw material(s) used to manufacture a new FBR MOX fuel, with forming and densification of the material, all this based on processes and technologies which can be extrapolated to increased plutonium flows (production rates and content) and specific isotopes of plutonium,
- management of effluents and waste whose nature is significantly different from that of LWR fuels, in particular if FBR fuels with high burn-up fractions and little cooling are processed,
- monitoring and instrumentation, in particular for the control of processes which integrate a more demanding material follow-up due to the management of higher plutonium concentrations and/or contents,
- integration studies making it possible to correctly assemble the architecture of a facility containing all the processing and recycling functionalities, using technological innovations (for example in terms of automation, remote operation, maintenance).

For each main subject of interest, technological changes are more particularly searched for, in order to structure the proposals for intermediate R&D steps, some of which are carried out in cooperation with Areva NC:

- for the process head-end, a dissolver/digester assembly for FBR MOX fuels; this assembly will be compact (with safe geometry) and will have a high processing capacity; it will be dedicated to plutonium quantitative recovery,
- for separation, a simplified process including only one cycle and no longer using redox reagents to recover the purified plutonium and uranium,
- for the conversion of plutonium and uranium, then for the manufacturing of FBR mixed fuels, a co-conversion / manufacturing integrated facility based on simplified and compact processes and technologies, allowing operation and maintenance in glove boxes and minimising the retention of materials,

- for effluent and waste management, creation of representative inactive technological platforms by 2020, to prefigure the industrial facilities for conditioning of the specific waste of FBR fuels, as well as solutions (to be extrapolated to an industrial scale) for optimised management of gas radionuclides (minimised impact),
- for process control, development of a set of sensors able to operate in severe nuclear environment, for on-line measurement and for the design of advanced control system integrating process simulation and data processing, for real time control of key operations.

7.3. FUEL CYCLE WORKSHOPS

The fuel cycle of Astrid integrates the manufacturing of the fuel (FBR MOX) and the multi-recycling of plutonium, as well as the gradual demonstration of the growth-transmutation separation of some minor actinides. Due to the impact on the characteristics of Astrid (see Chapter 5.1), priority is given to americium recycling.

The operations related to the material cycles of Astrid are aimed at achieving various requirements:

- allow the technical demonstrator to be supplied with fuel, with initial loading at an annual rate of 10 metric tonnes of U+Pu then, for renewal, at a rate of approximately 6 metric tonnes of U+Pu per year; the Core Manufacturing Facility (AFC), which will be set into service around 2020, fulfils this requirement,
- manage the unloaded fuel, and in particular ensure its processing and recycling within Astrid (thereby allowing recurrent recycling of plutonium and uranium within the reactor, and also perhaps making it possible to experiment the technological changes which can be considered for the

industrial processing of future fuels); the Used Fuel Processing Facility (ATC), which will be commissioned around 2030, fulfils this requirement,

- prepare transmutation experimentations, which are one of the missions of the Astrid technological demonstrator, on a scale which still remains to be defined at this stage of the project; a gradual approach can be considered, starting using the existing CEA facilities (Atalante and LEFCA) for the manufacturing of these experiments; to achieve the manufacturing of complete subassemblies, extensions of the ATC and AFC will be necessary after 2030.

7.3.1. CORE MANUFACTURING FACILITY (AFC)

Although it is composed of oxide ceramic pellets manufactured by powder metallurgy and sintering, as the LWR fuels (UOX and MOX), the fuel for the FBR core of Astrid has a specific design in comparison to these fuels. The main differences lie in the plutonium content, which ranges between 15 and 30% of heavy metal, depending on the concepts, the annular geometry of the pellets, the design of the fuel pins with spacing wire and the design of the subassembly composed of the bundle of pins positioned in a massive hexagonal tube. There are no more industrial facilities in the world able to produce this type of fuel with the necessary capacity; therefore, this requires a dedicated facility to manufacture this fuel. The new Core Manufacturing Facility (AFC) is therefore associated with Astrid to supply the fuel for the first cores, in the form of new subassemblies, then to supply fuel for reloading (according to the manufacturing flowchart of Figure 7.2) from various uranium and plutonium oxide raw materials and from structure parts.

FIGURE 7.2: FLOWCHART FO THE FUEL ELEMENT MANUFACTURING PROCESS

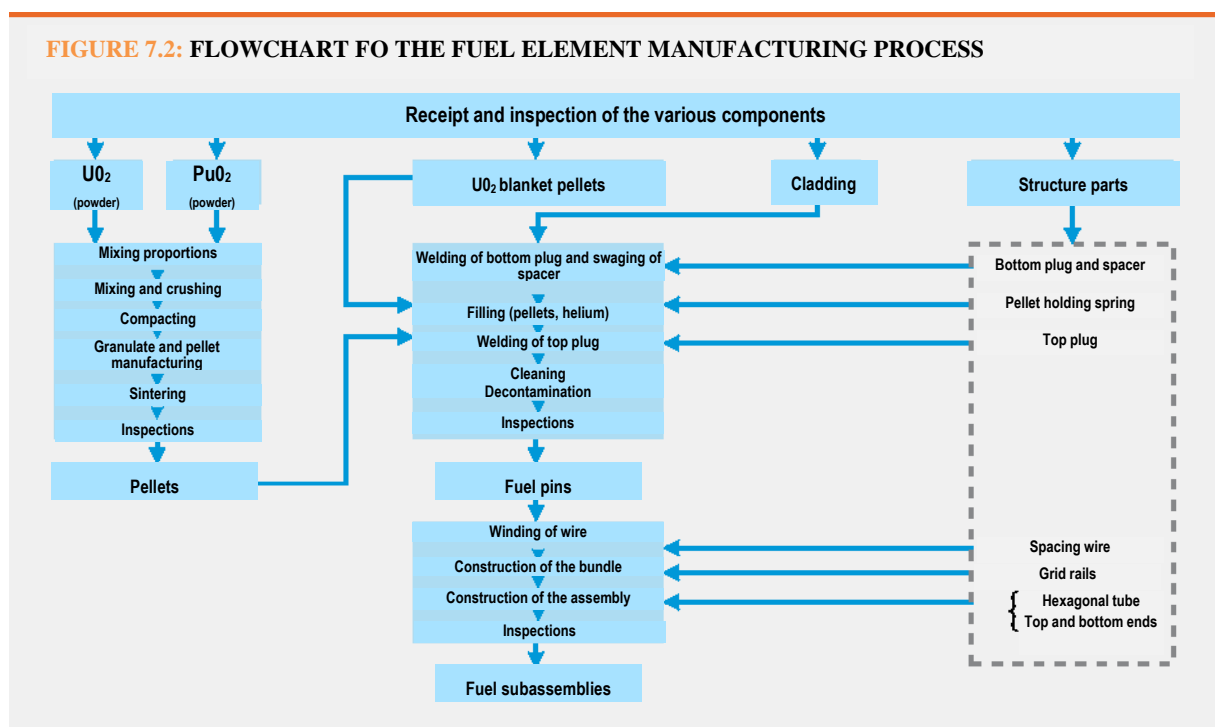



The major structuring assumptions for the current AFC project are as follows:

- a nominal annual capacity of 10 metric tons of heavy metal ($10 t_{HM}$) to manufacture the core of Astrid in three years. This implies that this facility must be set into service three years before Astrid,
- at the beginning, the oxide fuel will be manufactured from PuO_2 and UO_2 powders, using the COCA process already implemented in the plutonium technology facility (AtPu) of Cadarache for the Phenix and Superphenix fabrications. Then, the objective will be to simplify the fuel manufacturing process by using a co-converted $UPuO_2$ powder, which should reduce the radiological impact on the operators. The site for the construction of the AFC will be selected in 2013, after an orientation study.
- The AFC must be designed to allow for future evolution of the process and technologies and it must allow fuels of different specifications to be manufactured. One example is the integration of the ODS steel cladding which cannot be selected for the first core.

The studies for the basic preliminary design of the AFC started in 2012 in cooperation with Areva NC. The purpose of these studies is to define the first outlines, define the preliminary safety options and prepare the first master schedules. Simultaneously with these design studies, CEA is implementing all the other activities necessary to manufacture cores for Astrid, among which procurement of nuclear raw materials (in particular plutonium) and metallurgical materials for the subassembly structures.

Concerning the last point, the core of Astrid is composed of several families of subassemblies necessary for its operation and for the protection of the components of the nuclear island. All these subassemblies are comprised of several subcomponents, mainly made of steel, which need to be procured to manufacture the cores. Based on known design elements and on an analysis of the Phenix and Superphenix experience feedback, the short-term studies are aimed at providing the necessary elements to propose procurement strategies, including the questions of scheduling, risks and cost. First, an exhaustive list of the steel structures which are to be manufactured for the first core of Astrid has been drawn up to define actions aimed at reactivating the industrial sector. These actions will make it possible to assess, among others:

- the manufacturing processes which can be considered and the suppliers which master these processes,
- the possibility to implement R&D actions to clear all uncertainties related to the industrialisation of these processes, in cooperation with the designers of the core.

A certain number of priority actions has already been identified concerning, in particular, the cladding made of austenitic steel 15-15Ti-AIM1, the hexagonal tube made of steel EM10 and the neutron-absorbing elements made of B_4C enriched boron carbide.

The design and construction of the AFC are also a major opportunity to:

- make good use of the experience acquired on the manufacturing of FBR fuels, according to two approaches applied simultaneously during the design phase; on the one hand re-appropriate and improve the processes formerly used in the AtPu and, on the other hand, innovate on these processes and technologies,
- learn lessons from the past, based on the operation and the continuous progress areas of the MELOX plant,
- use, in a second step, new raw materials, in particular uranium and plutonium co-converted into mixed oxide $(U,Pu)O_2$, these materials being potential sources for major simplifications of the mixing steps (removal of the co-crushing operation) and, more generally speaking, of operations which involve powders,
- illustrate plutonium multi-recycling by reusing the plutonium formed during the use of this fuel in the core of this FBR, which implies to process the Astrid fuel to recover the reusable materials, mainly plutonium, taking advantage of the best processes designed from the R&D performed in this field.

7.3.2. USED FUEL PROCESSING FACILITY (ATC)

Studies have also been initiated to obtain a first image of the facility which will process the used fuels unloaded from Astrid. Several objectives have been set for this facility which must make it possible to:

- extract the plutonium contained in the fuels of Astrid in order to allow its multi-recycling in the reactor,
- produce the minor actinides, in particular americium, necessary to perform transmutation experiments at the scale of a subassembly,
- qualify, at a significant scale, innovative options for the processing of plutonium-loaded fuels (MOX-LWR and MOX-FBR).

In agreement with these objectives, two options are possible for the processing of the Astrid fuels: processing in a completely new facility specifically designed for these fuels, or processing within an existing plant. Two different facility configurations have been defined, associated with these options.

The first configuration corresponds to a self-contained facility which could be installed on the same site as the reactor, and the second configuration corresponds to a facility with restricted functionalities located on the La Hague site and which would use existing facilities for a large part of the processing operations. In the latter case, the uranium and plutonium extraction operations in the current plant require to dilute the nuclear materials stemming from the Astrid fuels with depleted uranium, reprocessed uranium or used fuel with a lower plutonium content than the FBR fuel.

Innovative processes have been selected for the two configurations. This selection has been made from R&D orientation elements for the multi-recycling of plutonium and from the results of the current studies concerning the separation and conversion of minor actinides.

As the processes are defined, the dimensions of the main equipment have been determined for an annual processing capacity of approximately 6 tonnes of initial heavy metal (t_{IHM}) of fuels. The size of the various process cells has been assessed from the dimensions of the equipment and from assumptions on the location of this equipment in the cells. In addition to the process cells, the facilities include intervention cells and also work, circulation, ventilation and fluid distribution areas.

The layout of the process cells and associated premises has been performed in order to obtain an image (with dimensions) of each facility configuration, as illustrated by the schematic diagram of the self-contained facility (Figure 7.3).

This preliminary study was based on technical assumptions (selection of processes and equipment, thickness of biological protections, interfaces with the core manufacturing facility and the reactor) which will have to be assessed more accurately during the future specification and preliminary design steps.

FIGURE 7.3: ILLUSTRATION OF THE USED FUEL PROCESSING FACILITY (ATC) (SELF-CONTAINED FACILITY VERSION)



7.3.3. FACILITY FOR THE MANUFACTURING OF ELEMENTS CONTAINING MINOR ACTINIDES

The transmutation of minor actinides in the fourth generation FBRs can be performed in homogeneous or heterogeneous mode. The approach to qualify these new concepts of nuclear fuels containing minor actinides requires 4 successive phases:

- selection of the concepts,
- feasibility study at the pellet scale or irradiated short pin scale,
- optimisation validating the behaviour of the full-scale pin in reactor,
- qualification of the complete subassembly corresponding to the industrial product.

For each phase, there are different scales of objects to be irradiated and different quantities of material to be produced, requiring different sizes of facilities.

Whatever the minor actinide recycling mode, the currently available data concerning the fuels that contain these actinides corresponds to the feasibility phase. Therefore, the irradiations in the Astrid reactor will allow the optimisation and qualification phases to advance. To support the approach selected for the heterogeneous transmutation experiments, the irradiation programme associated with the optimisation phase requires approximately 20 fuel pins to be manufactured (corresponding to approximately 15 kg of fuels) at a minimum production rate of 1 to 2 pins per year. This programme requires a minor actinide fuel production capacity greater than that of the experimental equipment currently available in CEA's nuclear facilities.

To first meet this need for production of americium-bearing fuels and targets for irradiations in Astrid, studies are carried out to assess the capability of existing facilities (Atalante shielded cell chains in Marcoule for the manufacturing of pellets, and glove box lines of the LEFCA in Cadarache for the manufacturing of pins) to receive the necessary equipment (such as, for instance, pellet press, sintering furnace or fuel pin manufacturing line with installation in cladding). Therefore, these studies concern the nuclearisation of remote-operated manufacturing and inspection equipment in shielded cells, and the improvement of contamination management in particular through the use of minor actinide co-converted powders.

In a more distant future, it may be decided to extend the ATC and AFC facilities to carry out the separation of the actinides to be recycled and manufacture the associated fuels, up to the manufacturing of complete subassemblies.



SIMULATION AND CALCULATION CODES - QUALIFICATION	67
8.1 Modelling tools according to the schedule of the project	67
8.2 Facilities of interest for the qualification of the core and the components of Astrid	68

8

SIMULATION AND CALCULATION CODES - QUALIFICATION

The qualification of the option selections for the Astrid project is a process which requires to refine, as the project progresses, the knowledge acquired on dimensioning parameters for each reactor component and on the phenomena which affect the operation of these components and their coupling, all this in order to guarantee the safety level of the reactor in the end.

Therefore, it is necessary to characterise, through calculation, the main parameters of the reactor and associate these calculations with a reliability index to assess the impact of the various sources of uncertainty which may be caused by:

- Possible modelling bias (notion of systematic uncertainties),
- Random uncertainties which can be modelled by means of a probabilistic model (based on often statistical mathematical processing),
- Epistemic uncertainties (associated with insufficient knowledge) which can be either modelled in a probabilistic way or taken into account through specific methods.

Finally, it is necessary to integrate the propagation of these uncertainties through connections between subjects.

Modelling of uncertainties will be based on the existing large experimental databases of observable magnitudes representative of the operating range of the reactor (normal or accident operation) which will be completed during the Astrid project phase when its specific design options are selected.

8.1 MODELLING TOOLS ACCORDING TO THE SCHEDULE OF THE PROJECT

The modelling tools used and the wanted level of accuracy for calculations are strongly dependent on the progress of the project:

2010-2012: Preconceptual design Phase (AVP1).

The design studies during this phase will be carried out with existing tools.

During this phase, the studies will be aimed at confirming the feasibility of the various systems or options considered and at performing a preliminary dimensioning of these systems.

The Preconceptual Design Phase studies do not require very detailed modelling, and the calculations must make it possible to obtain, within reasonable deadlines, results for the normal operation and for some accident situations so as to carry out sensitivity studies. The expected recovery time is usually estimated to a few hours, but of course system calculations or CFD (Computational Fluid Dynamics) calculations may involve much longer recovery times (in particular for calculations for verification of simplified modelling in support to design, or for example system calculations requiring a modelling of the

secondary system, or depending on the selection of Astrid options involving asymmetry studies as from the Preconceptual Design)¹⁴¹⁴.

This phase is characterised by many studies related to the large number of options and designs to be assessed and which do not require a high level of accuracy and definition. The calculation results obtained during this phase do not include uncertainties. The calculation tools used may rely on a first validation stemming from the experience feedback of the Phenix and Superphenix 1 programmes.

2012 – 2014: Conceptual Design Phase (AVP2).

In late 2012, the selection of the reference options for the technological demonstrator will be known and the number of options will therefore be smaller than in Phase 1. The objectives of the studies associated with this Phase 2 (conceptual Design) are as follows:

- define the dimensions of the reference components and systems, based on more detailed modelling, and assess the performance according to the operating conditions,
- define a first consistent overall installation file of the reactor and the various associated systems, requiring complex studies at reactor scale and integrating a large number of systems,
- carry out studies on accident transients to support the Safety Options Report (DOS).

Accident/incident transients will have been defined previously, depending on the safety strategy.

The calculation results obtained integrate in this phase a preliminary assessment of uncertainties.

If the tools are changed for the basic design, the transition phase for users will be performed during the AVP2 phase, from 2012 to 2014.

2014-2017: Basic Design Phase (APD).

Considering the advanced design level of the various systems which constitute the Astrid technological demonstrator during this phase, the associated studies and calculations will be extremely detailed, and they will require fine 3D modelling. The results of the design studies will integrate the uncertainties consolidated with the first qualification tests which will be carried out in the scope of the Astrid concept design substantiation plan.

¹⁴ – The recovery time only concerns the calculation time itself, and it does not include the data preparation and result interpretation steps.



Coupling between codes will have to allow complete calculations to be carried out with a high level of accuracy. The tools will be validated in the fields consistent with the Astrid design options, the operating conditions and the geometrical fields processed.

A first validation level for the simulation tools is required for the end of the APD phase as a support to the Preliminary Safety Report. This first level will be based on the available results of the qualification plan, and it will be completed during the next phases of the project through addition of the complements of the qualification programme in order to bring the missing elements for the first Safety Report.

8.2. FACILITIES OF INTEREST FOR THE QUALIFICATION OF THE CORE AND THE COMPONENTS OF ASTRID

The analysis of the need for new experimental data for the qualification of the Astrid reactor components and the reduction of uncertainties has already been initiated, in particular to identify:

- The existing experimental facilities in which it will be possible to carry out the required qualification programmes;
- The experimental facilities necessary but not available in France.

In this case, two scenarios are possible:

- Determine whether such a facility exists abroad and if cooperation is possible with the country concerned, in cost and deadline conditions compatible with the Astrid project;
- Study the opportunity to invest in a new experimental facility.

This course of action has been initiated in the three major fields below:

- Qualification of the core and associated facilities. This mainly concerns:
 - Neutron tests (in the BFS and Masurca critical mock-ups);
 - Severe accident tests (mainly with the Plinius platform suitable for the sodium coolant, and the IGR experimental reactor in Kazakhstan, and the analysis of the EAGLE experimental programme carried out by JAEA);

- Irradiation programmes to qualify, among others, some of the options defined for the fuel, the cladding or the transmutation of minor actinides. In this respect, let us mention the irradiation tests of structure materials in progress in the BOR-60 Russian reactor and the project of fuel irradiation in the BN-600 reactor;
- Qualification tests on subassemblies, among which specific subassemblies of the SEPIA type (SEntinelle for Passive Insertion of Antireactivity) and rods (including the mechanisms);
- Tests to more particularly qualify a model or a code (simulation of fluid-structure interactions, for example).

- Technological facilities of interest for the qualification of large components of the nuclear island, the primary circuit and the transverse functions (ISIR, handling, etc.) of the Astrid project or for out-of-reactor tests dedicated to severe accidents.
- Qualification of the safety action integrating the severe accident issue as from the design phase. In addition to the studies associated with the design of the core, this safety action requires experimental complements associated with the possible routes of the corium towards a core catcher and the control of long-term cooling of corium on the core catcher, based in particular on the Fournaise project facility (Plinius platform).

We can already describe four major loop families to comply with the requirements of the Astrid project:

- The large loops for in-sodium qualification tests of components (handling system, subassemblies, etc.) or for the advanced cleaning processes; these loops are gathered in the Cheops platform;
- The small loops for in-sodium tests, these loops being located in the Papyrus platform (Fleet of Small Facilities for Research on the Use of Sodium in fast reactors);
- The simulating fluid loops located in the Giseh platform (Group of Water Simulating Facilities for Hydraulic Systems), see Figure 8.1;
- The facilities dedicated to the study of severe accidents, located in the Plinius platform.

FIGURE 8.1: EXAMPLE OF PHENOMENA WHICH CAN BE STUDIED WITH SIMULATING FLUID MOCK-UPS

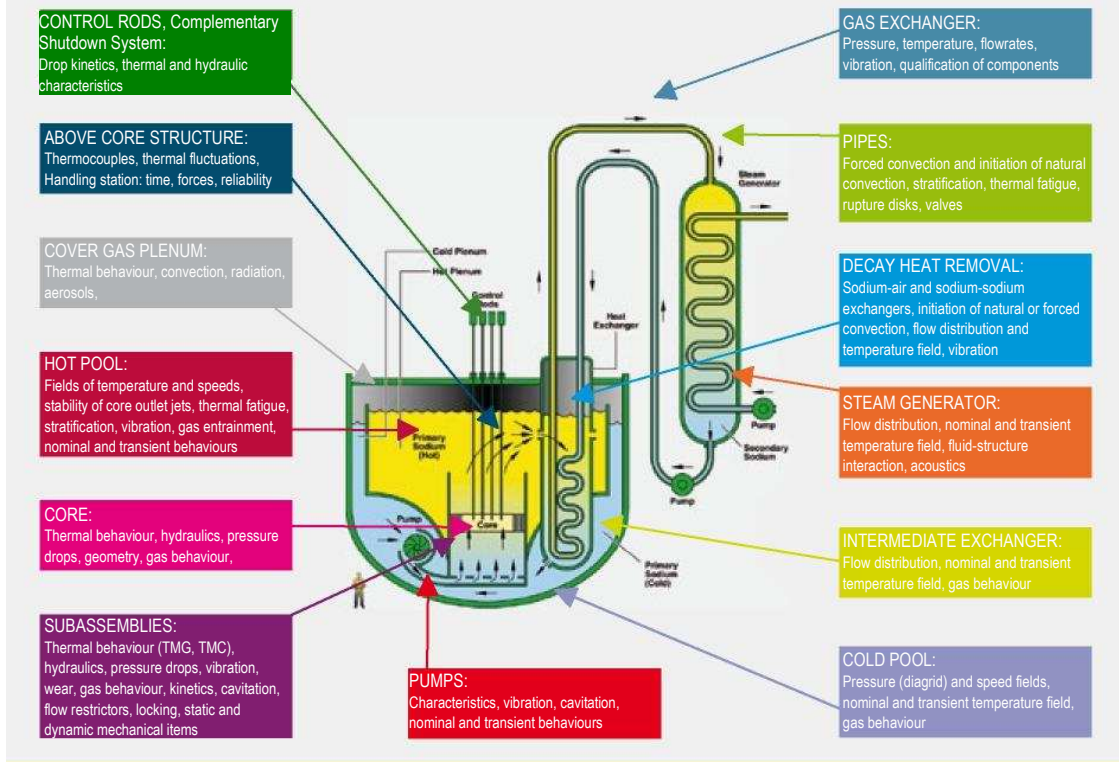



9.

9.	INDUSTRIAL ORGANISATION AND INTERNATIONAL COOPERATION OF THE ASTRID PROJECT	71
9.1	Industrial organisation of the project.....	71
9.1.1.	Missions of the contracting authority	72
9.1.2.	CEA internal organisation	73
9.2.	International cooperation	73
9.2.1.	In Europe	73
9.2.2.	Outside Europe	74

9.

INDUSTRIAL ORGANISATION AND INTERNATIONAL COOPERATION OF THE ASTRID PROJECT

9.1 INDUSTRIAL ORGANISATION OF THE PROJECT

By virtue of the act of 28 June 2006, CEA was selected as the contracting authority for the project and it also received the funds corresponding to the preliminary design phase (2010-2017), through the “Investment for the future” Programme (PIA).

The main principles of the organisation implemented are as follows:

- the Nuclear Energy Division / Innovation and Industrial Support Directorate, and more particularly the “4th Generation Reactors” programme, is the contracting authority and the strategic manager of the project,
- operational management of the project is performed by the Astrid Project Team (CPA) which reports to the Reactors Studies Department (DER) of CEA Cadarache; this unit is led by a project manager who relies on a team which includes the following:
 - an industrial architect, since CEA decided not to turn to a contractor and to carry out the function of lead contractor by itself; the industrial architect relies on a configuration synthesis and control cell,
 - a person in charge of project management; this person is in charge of organisation, risk control, scheduling and cost follow-up; this person relies on external assistance,
 - persons in charge of transverse functions for the major stakes of Astrid (safety, operability, value analysis, experimental programmes, instrumentation and ISIR),
 - persons in charge of the management of the various engineering study batches (site interfaces, nuclear island, core, power conversion systems, nuclear auxiliaries and handling, electrical distribution and instrumentation & control, civil engineering).

The project is broken down into engineering design batches which are entrusted to different industrial partners, preferably within the scope of two-party cooperation agreements, or via commercial contracts, except for the core engineering batch carried out by CEA for the preliminary design phase. To date, agreements have been entered into with the following:

- EDF/SEPTEN (since September 2010) which provides assistance to the CEA project management team through direct presence within that team and by means of a team based in Lyon (France); EDF/SEPTEN provides its skills as an architect and operator of PWR and FBR nuclear power plants. Let us also mention the support of EDF R&D, which has been taking part in the R&D studies with CEA and Areva since 2007 to assess options for a 4th generation SFR and, since 2010, more particularly in the R&D in support to the design of the Astrid reactor,

- Areva NP (since October 2010), which is the sole European manufacturer able to design sodium-cooled fast breeder reactor power plants and which provides engineering for the nuclear island, the nuclear auxiliary systems and the instrumentation & control system,
- ALSTOM POWER SYSTEMS (since May 2011), which designs and manufactures power conversion systems for nuclear or non-nuclear plants and which carries out the studies of the Astrid power conversion system,
- COMEX Nucléaire (since July 2011) which brings its skills as a mechanical equipment designer for the study of various systems, in particular robotic systems for in-service inspection of the primary system, or the diversified design of control rod mechanisms, etc.,
- TOSHIBA (since April 2012) for the development and qualification of large electromagnetic pumps for the secondary sodium systems,
- BOUYGUES (since April 2012) whose contribution mainly concerns the design of the civil engineering work for the buildings of the nuclear island (including the reactor building, the nuclear auxiliary buildings, the fuel handling buildings, etc.) and also for the turbine hall which contains the turbo-alternator set,
- JACOBS Nucléaire (since June 2012) for the engineering of the infrastructures and common means of the site,
- ROLLS-ROYCE (since September 2012) for the sodium-gas heat exchangers and the handling of fuel subassemblies,
- ASTRIUM (since October 2012) for performance reliability of equipment important to safety.

The project remains open to other partnerships, whether with French or foreign partners.

These partnerships allow CEA to work on the Astrid conceptual design studies by associating major players whose experience and competence in their own fields will be a guarantee for success. The association of industrial partners fosters innovation and guarantees that the industrial stakes (operability, constructability, etc.) will be taken into account as from the design phase of Astrid.

The relationship with the industrial partners in charge of engineering studies has been detailed in a management specification (which engineering departments respond to with a management plan) which stipulates, among others:

- project reviews in the meaning of standard RG aero 0040 and which are major meeting opportunities at the end of the AVP1 phase (SDR: System Design Review) and at the end of the AVP2 phase (DDR: Detailed Design Review),
- design reviews within the engineering departments, in particular before the SDR and the DDR,

FIGURE 9.1: GENERAL ORGANISATION OF THE ASTRID PROJECT

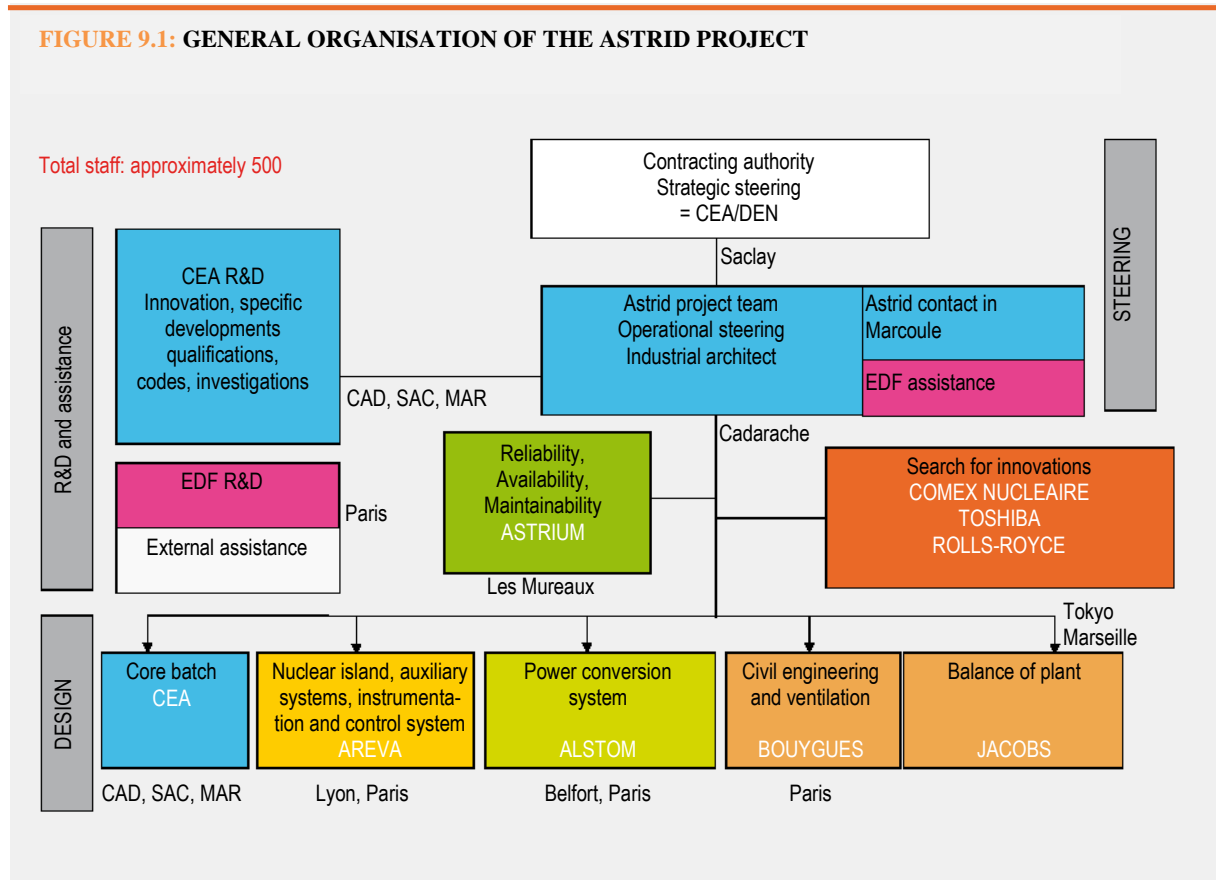

- option selection processes organised by the Astrid Project Team (CPA) with participation of the strategy officer,
- monthly progress meetings to take stock of the progress of actions, the schedule analysis, the supply of deliverables, physical progress,
- quarterly progress meetings to deal with budget aspects (annual budgets, multi-annual budgets, committed budget, remaining budget to be committed) and the project risk mitigation actions,
- bimonthly meetings for coordination of the Astrid engineering teams to deal with change datasheets, configuration management, performance reporting activities, integration of engineering models into the overall Astrid model,
- concerting reviews with steering entities, held between the strategic leaders of each partner.

The general organisation of the project is illustrated on Figure 9.1.

9.1.1. MISSIONS OF THE CONTRACTING AUTHORITY

Main contracting authority

As the contracting authority, CEA performs the strategic and operational steering of the project. CEA has also the responsibility for the preparation of the safety options reports and remains the contact point for the French Nuclear Safety Authority.

Since Astrid is a CEA project, it is managed in accordance with CEA's quality assurance rules, in particular the project management methodological repository (R2MP) based on recommendation RG AERO00040.

As the architect and lead contractor for the project, CEA has specific missions.

Configuration management

The architect and lead contractor is the guarantor of the management of the configuration studied by the various engineering teams. Thus, a product breakdown structure has been finalised and shared among all the parties involved. Each assembly itself is broken down into basic subassemblies or systems.

These studies of the preliminary phase made it possible to identify, within each subassembly, a certain number of variants or options; most of them will be proposed for selection during the AVP1 phase, then during the AVP2 phase for the remaining ones. They are all listed in the "product" breakdowns and they form the subject of consistent layouts in compared performance designs. All these designs comply with the functional specifications.

Identification and management of interfaces

All the technical data from the functional specifications and the first data from the preliminary studies of the engineering batches is managed and shared under the responsibility of the industrial architect. A document is updated monthly and all the changes are reported to all entities which take part in the design of Astrid.

Performance management

For each studied configuration, the performance of the whole facility is reconstructed using a validated calculation methodology. This methodology must allow consistent combinations of models/variants/options (called “designs”) to be assessed and classified with respect to a reference design studied for each model (water/steam or gas power conversion systems) and proposed by the engineering teams, with validation of the CPA, during the option selection intermediate reviews. The classification is made with the essential discriminating criteria which are safety, cost and maturity/feasibility.

9.1.2. CEA INTERNAL ORGANISATION

The Astrid project team (CPA) is in direct relationship with:

- The team of the core engineering batch,
- The R&D entities on the Astrid project,
- The entities working on the cycle and the associated large facilities.

The internal organisation of the CPA is based on activity or transverse batch managers (see Figure 9.2) who interact with all the entities involved in the project, whether these entities are engineering or assistance teams. These batch managers specify to their respective contributors the input data, the deliverables to be supplied and the main milestones to which they contribute.

Outside the CPA, for the R&D teams and the AFCOE

(core manufacturing facility) project, functioning is based on the issuance of requirement expression sheets for technical batches (core, nuclear island, handling, power conversion system, etc.) and transverse batches (safety, ISIR, operability, etc.) from the CPA to the teams which take part in the core engineering batch (LIC) or which provide assistance to the contracting authority (in R&D, definition of qualifications and investigations).

9.2. INTERNATIONAL COOPERATION

Since 2007, CEA has developed several international partnerships in order to reinforce and multiply its R&D efforts. These partnerships are an opportunity to share the costs of development and use of large experimental infrastructures. This chapter presents a summary of these infrastructures and their targets.

9.2.1. IN EUROPE

In Europe, the SFR system and the Astrid technological demonstrator are integrated into the roadmap of the SNE-TP platform (Sustainable Nuclear Energy Technology Platform, www.snetp.eu) which aims at implementing a European research area in the field of fission, and into the roadmap of the ESNI (European Sustainable Nuclear Industrial Initiative), the equivalent of the SNE-TP supported by the industrial world, as well as into the EERA alliance (European Energy Research Alliance, <http://www.eeraset.eu>).

FIGURE 9.2: ORGANISATION OF THE ASTRID PROJECT TEAM (CPA)

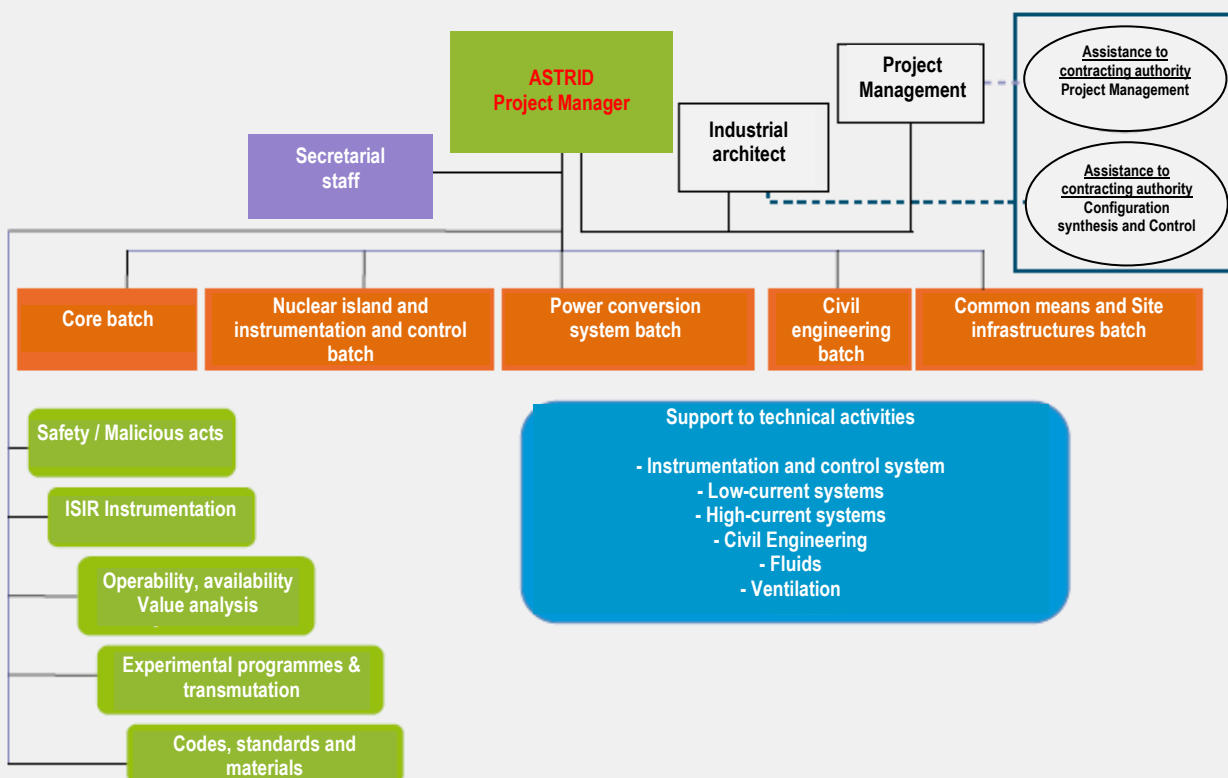

This system is identified by these platforms as the reference system for fast spectrum reactors. These platforms provide support to structure and rationalise the efforts made by the various European contributors. These actions also appear in the implementation of several European projects, the main ones being:

- CP-ESFR (<https://www.projectcpesfr.eu/>), coordinated by CEA, and focused on the development of technologies and the validation of calculation codes;
- ADRIANA (<http://adriana.ujv.cz/>) which performed an inventory of the necessary European experimental infrastructures for the various Generation IV programmes, then issued an investment roadmap;
- MATTER (www.matterfp7.it) and GETMAT (<http://nuklearserver.ka.fzk.de/getmat/>), two projects dedicated to development and qualification of innovative materials;
- SARGEN IV, whose purpose is to contribute to the efforts for harmonisation of the safety evaluation methodologies for the 4th generation systems, as a continuation of the work of the Risk and Safety Working Group of the Generation IV International Forum and the recommendations of the IAEA and the WENRA.

These European projects also make it possible to support the implementation of specific partnerships between CEA and European R&D organisations.

9.2.2. OUTSIDE EUROPE

Outside Europe, CEA is a major contributor to the Generation IV International Forum (<http://www.gen4.org/>) which gathers 13 countries interested in sharing the R&D efforts on six systems, among which the SFR system, in the fields of transmutation, safety and technology. This Forum has a significant activity of harmonisation of standards and safety reference documents, via the Risk and Safety Working Group.

CEA is also involved in a certain number of activities of the IAEA within the scope of the Technical Working Group on Fast Reactors (TWGFR), and the International Project on Innovative Nuclear Reactors and Fuel Cycles (INPRO), which allow exchanges concerning the safety and the technological development of fast nuclear systems as well as sharing the experience feedback from phases of construction, operation and dismantling of SFRs.

In addition to these multilateral collaborations, CEA has developed a set of two-party partnerships with all the R&D organisations involved in the development of SFR systems. Among others, we can mention the following:

- With Russia, further to the signature of the CEA-Rosatom agreement in the summer of 2010. Three R&D areas were defined: development and qualification of core materials and fuels (including irradiations in the BOR-60 and BN-600 reactors, for instance), safety and physics of cores (including neutron tests in the BFS mock-up to support the qualification of the CFV core), and technology with in particular the assessment of the possibility to share experimental loops. Furthermore, common CEA-ROSATOM work is in progress to issue a roadmap for the development of a commercial sodium-cooled fast neutron reactor.
- With India, common R&D is carried out with IGCAR (Indira Gandhi Centre for Atomic Research) and BARC (Bhabha Atomic Research Centre) concerning safety and basic research, in compliance with international treaties. A few examples of R&D are the improvement of the understanding of the mechanisms of corium propagation within an SFR, the impact of sodium aerosols within the facility and in the environment as well as the development of the safety instrumentation, based on tests performed jointly.
- An agreement was entered into in 2010 with JAEA (Japan) and the US DOE (United States), in order to reinforce the cooperation to support the developments of the Astrid and JSFR prototypes. Common actions are in progress, associated with the validation of calculation codes in the fields of thermal hydraulics and severe accidents and with the development of instrumentation and robotic systems. Common actions are also in progress to improve the safety standards to support harmonisation efforts and they are associated with the schedules of the two prototypes. Furthermore, this agreement allows the use of partners' experimental resources as, for example, wastage tests performed in 2011 in sodium-water reaction situations on the JAEA's SWATIR facility, and the participation of CEA in the EAGLE 1 & 2 programmes conducted by JAEA on the IGR reactor of NNC (Kazakhstan) to support the qualification of mitigation devices.
- In China, the CEFR experimental reactor was critical for the first time in 2010. A common laboratory was created by CEA and CAEA to provide support for the starting phase of the CEFR experimental reactor and prepare experimental programmes.



10.

SCHEDULE AND COSTS.....77
10.1. Schedule.....77
10.2. Cost assessment.....78

10.

SCHEDULE AND COSTS

In late 2012, the Astrid project is still in a preliminary phase, since the conceptual design will be completed only in late 2014. The studies performed by the various engineering teams do not have the same maturity level, due to the fact that they started at different times during the preconceptual design phase (AVP1): beginning of the core engineering studies as from the setting up of the project team at the beginning of the year 2010, then beginning of the nuclear island engineering studies in September 2010, then beginning of the studies of the power conversion system in June 2011, and beginning of the studies for civil engineering, common means and infrastructures in early 2012. Furthermore, to provide room for innovation, some technical solutions have not been decided yet (for example, selection of the technology for the power conversion system). Finally, the work to consolidate the engineering studies of the basic preliminary design level is scheduled to be carried out mainly during Phase 2, called AVP2 (conceptual design) (2013-2014).

In these conditions, the schedule of the project for the subsequent phases still remains to be consolidated. Concerning the costs, it is first necessary to share the same methodology which will allow a complete assessment at the end of the AVP2 phase.

10.1. SCHEDULE

Preparation and follow-up are performed at 3 levels:

The master schedule, rank 0 schedule: this is the reference schedule. This reference scheduling is “wide meshed” and

indicates the overall lead time for the project, the main deliverables to be produced, the main steps and their connections, the estimated durations and the milestones. This scheduling integrates margins which are consolidated by a risk analysis.

The rank 1 schedule: it has a narrower mesh for the started phases. This half-detailed schedule provides visibility for the logical progress of each batch and it highlights the key events; it is issued by the engineering teams and consolidated by the operational steering team.

The rank 2 schedule: this schedule is detailed down to the rank of detail tasks. It integrates the elements related to studies, work preparation, work performance, worksite cleaning up and submittal of the final files and experience feedback. This schedule is internal to the engineering teams.

Several different schedules are issued and followed up simultaneously:

- sequences of studies and construction of the power plant,
- schedule for the writing and analysis of the safety options reports and the associated authorisations,
- regulatory process: debate and public inquiry, building permit, etc.,
- process for the qualification of the core and major components,

FIGURE 10.1: OVERALL SCHEDULE OF THE ASTRID PROJECT

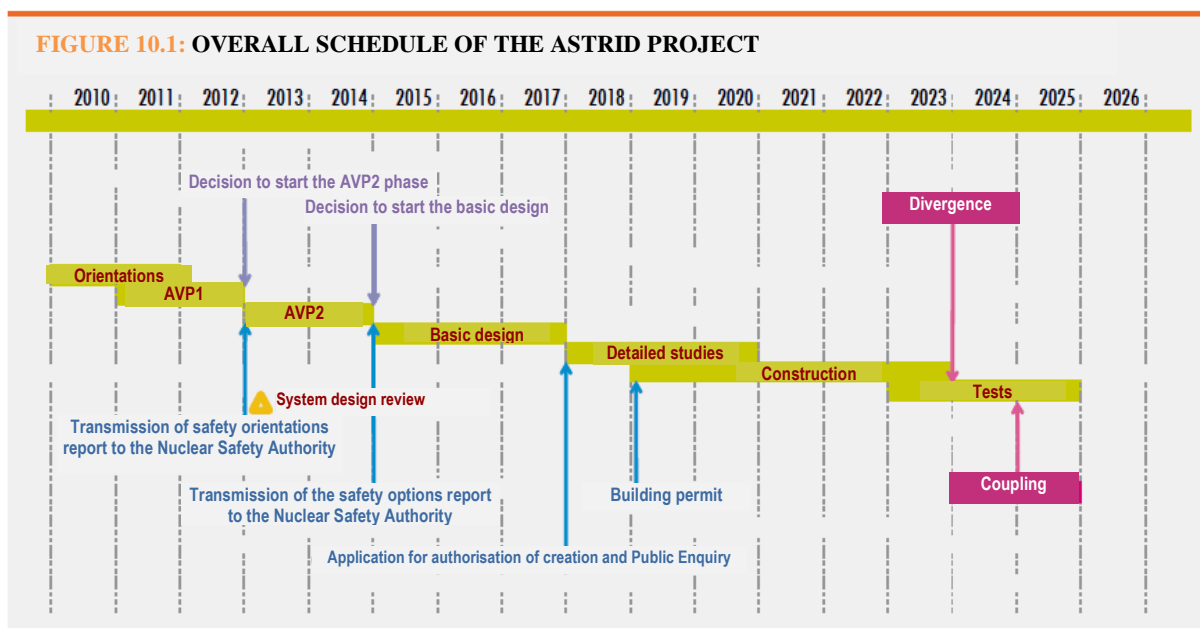

- studies for and construction of the core manufacturing facility.

Figure 10.1 illustrates the main steps of the overall schedule.

10.2. COST ASSESSMENT

To assess the costs within this phase located very upstream in the project, and in order to limit uncertainties, it is necessary to deploy several methodologies simultaneously and then consolidate the results obtained. The 3 assessment methods which were selected are as follows:

- An assessment performed within CEA using the SEMER software developed for the Superphenix2 and EFR sodium-cooled fast reactors, or using the experience feedback database which contains the costs of the work contracts recently entered into for various CEA facilities (ROTONDE, MAGENTA, AGATE) and for the RJH reactor, making it possible to define macro-ratios between the process on the one hand and the infrastructures and common means on the other hand.
- An assessment carried out by the engineering teams, analysed and consolidated by the contracting authority of the project. For the nuclear island, this assessment reuses and updates the cost bases which had been developed during the EFR studies.
- A assessment of the files by a third-party company, independent from the engineering companies concerned; this assessment is based on project costing techniques used in upstream phase.

The purpose is to cross-check these different approaches in order to limit as much as possible the uncertainties concerning the estimation of the end of the AVP2 phase, and also to obtain databases which will make it possible to start a value analysis action on Astrid as from these design phases in order to optimise the costs of the technological demonstrator.

This is why several actions have been initiated simultaneously to contribute to the consolidation of the estimations:

- value analysis on approximately fifteen subjects considered as relevant,
- comparative study with the techniques used in the oil industry, as this industry is also facing this problem of estimating the cost of major projects before making the decision to invest.



11.

CONCLUSION	81
11.1. Sodium-cooled fast reactors	81
11.2. Safety of SFRs.....	81
11.3. The Astrid technological demonstrator: objectives and specifications	82
11.4. R&D in the scope the Astrid programme	83

11.

CONCLUSION

The international framework for cooperation in the field of 4th generation nuclear systems is the GIF (Generation IV International Forum), whose purpose is to coordinate the necessary R&D work for the development of nuclear systems (reactors and fuel cycle) complying with the nuclear energy sustainability criteria.

Among the six concepts selected by the Forum, four are based on fast neutrons and able to achieve the objectives set to the fourth generation of nuclear reactors. These objectives are:

- capability of plutonium multi-recycling and making the best use of the uranium resource. This requires reactors operating in fast neutron spectrum, coupled to a closed fuel cycle;
- if this option is selected, capability to perform the transmutation of some minor actinides. This also requires fast neutron reactors;
- safety level equivalent to that of the 3rd generation reactors commissioned at the same period. For the Astrid technological demonstrator, this means a safety level at least equivalent to that of the 3rd generation reactors, with integration of the lessons learned from the Fukushima accident;
- achieving correct competitiveness in relation to the service provided;
- providing guarantees of resistance to nuclear proliferation.

It is to be noted that the concepts selected by the GIF have very varying technological maturity levels. For CEA, in view of the objectives set by the act of 2006, the effort needs to be focused first on the sodium-cooled fast neutron reactor (SFR) technologies and, to a smaller extent, in particular as regards innovation, on the materials, the fuel and the gas cooling technologies (GFR) for a more long-term vision.

11.1. SODIUM-COOLED FAST REACTORS

The fast breeder reactor (FBR) system has extremely significant advantages in terms of sustainable energy:

- plutonium recycling capacity, without limitation in the number of recyclings (multi-recycling), and optimised use of the uranium resource. Unlike the vast majority of reactors currently operated or under construction throughout the world, which consume approximately 1% of the natural uranium extracted from mines, FBRs are able to consume more than 80% of the resource. With the stock of depleted uranium currently available on the French territory, it would be possible to feed a fleet of FBRs for several thousands of years;

- FBRs are an intensive energy source, whose process does not release greenhouse gases;
- FBRs are able to burn minor actinides, while producing electricity, thereby significantly reducing the quantity, toxicity and life of ultimate radioactive waste.

In comparison with the well-known operating principle of a pressurised water reactor, let us mention the following specific points of SFRs:

- the primary system is integral with the main vessel, which contains the core but also the intermediate exchangers and the primary pumps; this provides remarkable containment of the primary sodium which is at atmospheric pressure;
- an intermediate sodium system is added as a barrier between the primary sodium and the power conversion system;
- the primary system is not pressurised and has a high thermal inertia which increases the “reaction time” in case of loss of coolant;
- the coolant has a very high boiling margin with respect to its normal operating temperature (typically 300°C);
- the pool type architecture of the SFR significantly improves natural circulation;
- as a result, it is possible to design diversified, active or passive decay heat removal systems which have been already tested, to remove the residual power in all circumstances;
- the collective dose which workers are exposed to is very low in normal operation, in comparison to other types of reactors.

SFRs have formed the subject of many projects worldwide, which made it possible to total more than 400 reactor-years of operation.

11.2. SAFETY OF SFRs

The safety demonstration concerns the following safety functions: reactor reactivity control, reactor cooling, reactor containment.

For many years, the objective of the R&D performed within CEA in partnership with EDF and Areva was to reinforce the lines of defence and the robustness of the demonstration for all these safety functions, in particular as regards the following points of SFRs, namely (non-exhaustive list):

- design of the core;



- decay heat removal systems;
- sodium-water reactions.

Therefore, CEA, EDF and Areva are working on the design of a CFV core (core with low void effect); the specific feature of this core is that it has a very low or even negative reactivity coefficient in case of sodium draining, unlike the previously designed reactors (a positive coefficient means that the reactivity of the reactor increases in case of disappearance of the sodium, due to boiling for example). It is important to note that this very promising work is not complete yet and that studies are currently in progress to confirm the potential of the design of such a core as regards the safety objectives. If such confirmation is obtained, this core will be an essential progress in the field of safety.

As regards decay heat removal, it is necessary to remind the importance of the notion of thermal inertia (i.e. the product of the bulk thermal conductivity of the primary fluid and the metallic structures multiplied by their heat capacity). The higher the thermal inertia, the higher the resistance of the reactor to a temperature rise in case of loss of the decay heat removal systems, and therefore the higher the resistance to fuel meltdown. The thermal inertia of an SFR is approximately twice that of a standard pressurised water reactor (PWR). If we also integrate the notion of boiling margin of the primary fluid, which is respectively approximately 30°C for a PWR and 300°C for an SFR, the maximum deadline before the primary fluid starts to boil is almost 20 times higher for an SFR than for a standard PWR.

Thermal inertia alone is not enough in the safety demonstration, and it is important to thoroughly consider the complete incident sequence, for example a complete loss of electrical power supplies, and assess which back-up means will still be available in such cases. Therefore, the previously designed and built SFRs were equipped with a combination of passive and active, redundant and diversified Decay Heat Removal (DHR) systems to evacuate the residual power as from the moment when the control rods fall, and this even in case of complete loss of the electrical power supplies and of the cold water source. As a matter of fact, some of these systems operate with passive natural circulation (thermosiphon) and use the atmosphere as the cold source. Their efficiency was verified through tests on the Phenix and Superphenix reactors.

Finally, for the sodium-water reaction, the objective is to design reactors which either completely eliminate the possibility of occurrence of such a reaction, through the use of an alternative fluid (a system that uses nitrogen instead of water is being studied on Astrid as one of the possible options), or guarantee the absence of consequences on safety should such a reaction occur despite the lines of defence implemented (concept of modular steam generators).

11.3. THE ASTRID TECHNOLOGICAL DEMONSTRATOR: OBJECTIVES AND SPECIFICATIONS

Based on the experience acquired with SFRs which operated in the past (in particular Phenix and Superphenix) or which are currently in service (BN-600 in Russia), CEA and its partners have set ambitious objectives for the Astrid reactor so that it can be, by design, a 4th generation reactor. The achievement of these objectives will be verified throughout the design and construction process.

Safety

The proposed objective for Astrid is to achieve a safety level equivalent to that of a 3rd generation PWR, together with the requirement of obtaining significant progress on the specific points of the SFR system (improved core behaviour, inspection, reaction with sodium, resistance to internal and external hazards etc.). These safety objectives are formalised in the WENRA¹⁵ document "Safety Objectives for New Nuclear Power Plants" (2010). The associated safety demonstration shall have the quality corresponding to the state of the art required by the French Nuclear Safety Authority. As from the design, Astrid will integrate the requirements which stem from the experience feedback from the Fukushima accident, knowing that SFRs intrinsically have a good resistance to this type of scenario, due to the high thermal inertia of the primary system.

Operability

It is required that Astrid can demonstrate, after a few years of operation, an availability factor comparable to that of the current fleet of reactors in service (i.e. approximately 80% of availability), after deduction of the penalties induced by certain experimental irradiations. This is made possible by the progress achieved in in-service inspection techniques and by the development of an innovative fuel handling system.

Minor actinide transmutation

Phenix made it possible to test the feasibility of minor actinide transmutation of an experimental scale. Astrid will be designed to continue the study of the feasibility of the transmutation of radioactive waste produced from used fuels, at a higher scale than what has been done before.

Investment cost

As a technical demonstrator of 4th generation fast breeder reactors allowing complete implementation of the closed cycle for nuclear fuels, Astrid must test the relevance of major innovations in several fields. A specific effort will be made to contain the investment costs as much as possible, as these costs are expected to be several billions of euros at this stage of the project for all the necessary facilities, and the contribution of industrialists to the project is a very useful guarantee in this field. It is also planned to apply modern value analysis tools to the design of Astrid, as these tools, with sufficient anticipation, allow substantial saving on this type of project.

15 – Western European Nuclear Regulators Association.

11.4. R&D IN THE SCOPE OF THE ASTRID PROGRAMME

The very innovative nature of the design of Astrid, in comparison to SFRs which have operated previously or which are currently in service, requires a significant R&D effort to demonstrate its feasibility and optimise the components and the operation.

Safety: design and more robust demonstration

- prevention and mitigation of the risks of core meltdown accident:
 - a) design of a very innovative core with very low or even negative void effect;
 - b) possible installation of additional safety devices in the core: SEntinel for Passive Insertion of Antireactivity (SEPIA) equivalent to a 3rd shutdown level, making it possible to reach a safe state of the reactor during a loss-of-flow accident or a loss-of-coolant accident without drop of the normal shutdown rods, systems of reinforced plates to eliminate the risk of core compaction;
 - c) robust design of the vessel bottom structures to eliminate the risk of failure of the core supporting structure, and integration of a core catcher;
 - d) core instrumentation with enhanced performance (thermocouples to monitor the temperature of the fuel subassemblies, fission chambers for neutron detection and fission product detection, ultrasonic testing technologies for displacement measurement, acoustic detection of boiling, flow measurements, etc.);
- practical elimination (in the meaning of IAEA) of the complete and prolonged loss of the decay heat removal systems: redundant architecture of the diversified, active and passive decay heat removal systems with absence of common mode failures for the systems (cold source: water but also atmosphere);
- elimination of large sodium fires: protection of premises, inerting of premises;
- elimination of violent sodium-water reactions with significant release of energy: two main approaches are under study: 1/ water-steam system: to reduce the quantity of reacting sodium, design of modular steam generators with improved hydrogen detection; 2/ replacement of the water-steam system with a nitrogen system, to completely eliminate the risk of sodium-water reaction;
- earthquake resistance: reactor building designed with seismic pads;
- state of the art as regards protection against external hazards (aircraft shell, flood protection, etc.) and integration of the experience feedback from Fukushima.

Operability and economic aspects: availability up to the standards of the industry

The design of Astrid will integrate provisions to:

- reduce the duration of the outage periods for fuel reloading: improvement of the handling system design;
- increase the burn-up fraction and the cycle duration;
- improve the manufacturing quality of pipes and vessels containing sodium;
- improve instrumentation performance for sodium leakage detection and location.

ISIR (In-Service Inspection and Repairability) is taken into account as from the design:

- simplification of the architecture of the primary system;

- objective for inspection of all structures whose failure is detrimental to safety (accessibility of structures, inspection from the inside, carrying robots);
- removability of components for repair or replacement;
- accessibility and available space around components and structures.

Finally, Astrid will be designed for a guaranteed service life of 40 years, with the objective of extension to 60 years, based on future R&D and based on the data which will be collected during its operation. The service life requirement for 4th generation SFRs (EDF specifications) is at least equal to 60 years, as for the EPR. For Phenix and Superphenix, the total service life planned during the design phase was 20 and 30 years, respectively. This service life will rely on selections of suitable materials, confirmed by relevant modelling (ageing), and based on the selection of some maintenance options.

The Astrid technological demonstrator is the key step to demonstrate the technical feasibility of a 4th generation reactor. Astrid will guarantee safety and security levels at least equivalent to those of the 3rd generation of reactors, by integrating the experience feedback from the Fukushima accident as from the design, and it will demonstrate significant progress in terms of operation on an industrial scale.

Therefore, the main objective of Astrid is to demonstrate the integration of technological progress by qualifying innovative options in the identified fields of progress (in particular safety and operability) and to serve as a test bench for the use of advanced inspection and repair techniques. Astrid will also have capacities of radioactive waste transmutation in order to demonstrate the feasibility of such transmutation on a significant scale.

The Astrid programme is composed of the following phases: construction of the Astrid reactor itself, construction of sodium loops for technological validation, validation of full-scale reactor components on these loops, construction of a core manufacturing facility (AFC) and of a fuel processing facility (ATC). According to the schedule set out by the act of 2006, the reactor shall be operational by 2020.

Therefore, over the period 2010-2012, CEA has initiated the first phase of a basic preliminary design intended to assess and define the innovative technical options and the safety orientations.

The second phase of the basic preliminary design is scheduled from 2013 to 2014. The basic design is currently scheduled between 2015 and 2017; after this period, the phase of the work and construction studies will start.

The Astrid design studies until the basic design phase (APD) inclusive are funded by the "Investment for the future" programme. This programme ("future nuclear" action) also covers the design studies for the Astrid core manufacturing facility and the renovation or construction of technological facilities for qualification of full-scale components. Until late 2017, a current amount of 625 M€ (initially 650 M€, but 25 M€ were used to fund a call for tenders issued by the French National Research Agency for safety studies following the Fukushima accident) is allocated to the Astrid programme under the scope of the "Investment for the future" programme. This amount is completed by investments made by industrial partners up to approximately 20% and by the credits mobilised by CEA to finance its personnel for the activities of contracting authority and R&D work (credits taken from the subsidy received from the French government).



CONCLUSION

Since 2010, CEA has been working in cooperation with industrialists which take part in the Astrid design studies through cooperation agreements which provide for contribution from the partners' equity. As a result, while CEA remains responsible for the overall architecture of the reactor, its core and its fuel, the batches below are provided by various industrialists:

- Areva: nuclear island, instrumentation and control system, nuclear auxiliary systems;
- EDF/SEPTEN: project management assistance, experience feedback from operation, safety studies;
- EDF R&D: contribution to the study of the core, in-service inspection and repair, materials (service life);
- ALSTOM: water-steam and gas (nitrogen) power conversion systems;
- COMEX Nucléaire: innovations on robotic systems, handling systems and rod mechanisms;
- BOUYGUES: civil engineering;
- JACOBS: balance of plant;
- TOSHIBA: electromagnetic pumps;
- ROLLS-ROYCE: sodium-gas exchanger, fuel handling;
- ASTRIUM: dependability.

The current result of these industrial collaborations is very positive. More than 500 persons (CEA and industrialists) are currently working on the Astrid project.

More generally, international collaborations are implemented with major players of the sodium-cooled fast reactor system (Russia, Japan, China, India, USA).



APPENDIX: SPECIFIC FEATURES IN THE DESIGN OF SODIUM-COOLED FAST REACTORS87

A.

APPENDIX: SPECIFIC FEATURES IN THE DESIGN OF SODIUM-COOLED FAST REACTORS

The schematic diagram of an SFR is presented in the figure below.

The core (Items 1 and 2), where the chain reaction and the production of energy occur, is immersed in a main vessel (Item 6) filled with sodium. The sodium temperature at the inlet of the core is approximately 400°C. This temperature reaches 550°C on an average at core outlet. The hot primary sodium then flows into an intermediate exchanger (Item 10) which transfers the heat of the primary sodium to the sodium of a second independent system called “secondary system” (Item 11).

After cooling, the primary sodium is returned to the core inlet by a supply pump (the primary pump) (Item 4) which is also immersed in the main vessel.

Then, the secondary sodium also transmits heat to a third system, here supplied with water. The energy transfer occurs within a steam generator (Item 13) which produces steam of excellent quality at a temperature above 500°C, thereby allowing an overall efficiency of the power plant above 40%. The steam from the steam generators is sent to a turbo-alternator set (Items 20, 21 and 22) which produces electricity.

The presence of the secondary system allows us to contain the primary sodium within the vessel and ensure external thermal

exchanges between a sodium which is not in contact with the core and, in this case, water (as we pointed out before, a gas power conversion system is currently under study to replace the water steam system).

The main vessel is topped by a slab (Item 9) used as a cover. The slab includes a rotating plug above the core to allow insertion and removal of the subassemblies, and to allow the penetration of the core control rod mechanisms (Item 3) and the core measuring devices.

The sodium is inerted by an argon cover-gas plenum (Item 9A).

A second vessel called “safety vessel” (Item 7) is used to mitigate the risk of leakage or failure of the main vessel by recovering the sodium and avoiding the core from no longer being immersed.

The diagram presented here is of the “pool” type, since the whole primary system and its components (pump, exchangers) is immersed in the main vessel. This type of design is the most widely used either in France or in Russia or India. Only Japan is developing another type of concept, the “loop” concept, in which the core is isolated in the main vessel and connected, by means of loops, to other vessels where the large components are located. The illustration of the two types of design is presented on Figure A.2.

FIGURE A.1: SCHEMATIC DIAGRAM OF A SODIUM-COOLED FAST REACTOR

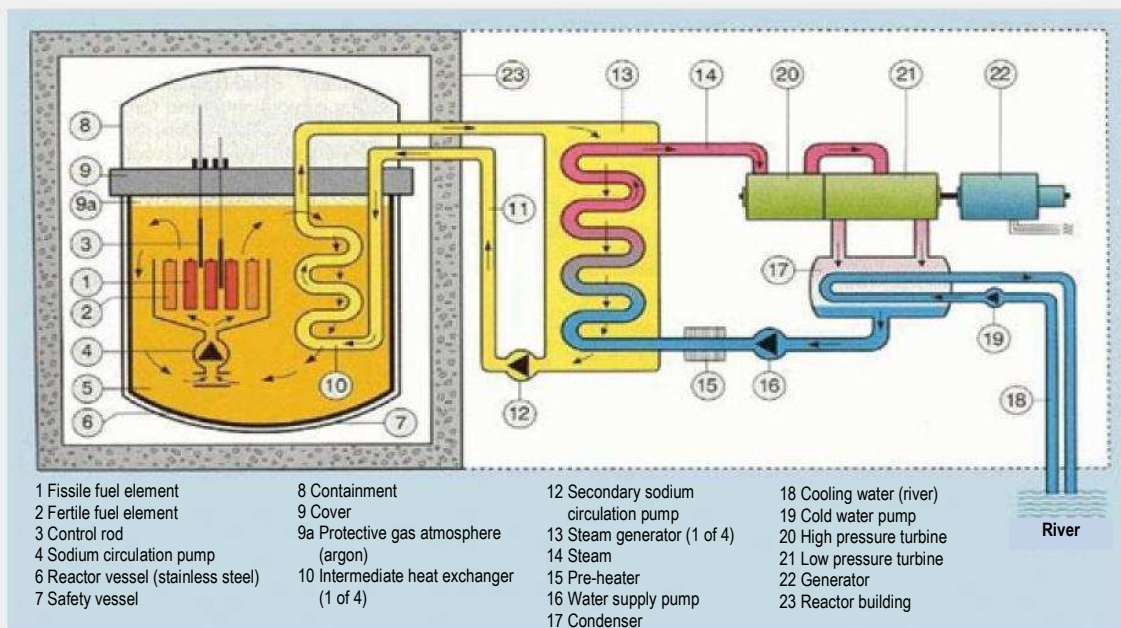
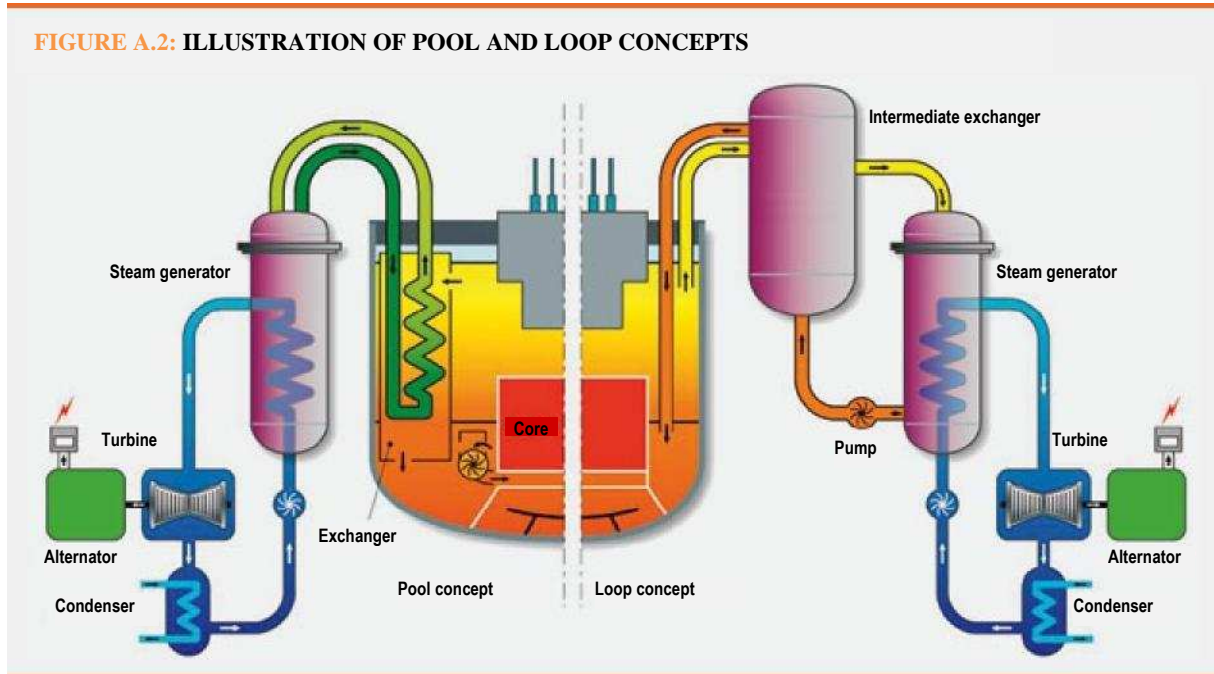

FIGURE A.2: ILLUSTRATION OF POOL AND LOOP CONCEPTS



The core

Obviously, the core has a key function. The fuel which constitutes the core is usually a mixture of mixed oxide (U,Pu)O₂ in the form of pellets with a diameter of a few millimetres, placed in sealed clads made of stainless steel. The pins formed in this way are grouped in a bundle or several hundreds of pins. A steel helical wire is wound around each pin to ensure sufficient spacing between pins and make sodium circulation and temperature homogenisation easier.

The bundle is then placed in stainless steel casings or hexagonal tubes so as to form subassemblies. The subassemblies are then inserted, from their bottom ends, into the receiving structure (the diagrid) to make up the reactor core.

Reactivity control is performed by two independent systems of boron carbide rods to absorb neutrons. The first system is dedicated to control and to the monitoring of the evolution of the reactivity during the cycle. The second system has a safety function and it drops by gravity to smother the nuclear reaction in case of emergency shutdown.

The operation of the core is monitored by fission chambers located within the core in order to measure the evolutions of the neutron population and, therefore, the reactivity of the core.

Temperature monitoring is performed by thermocouples located just above the sodium outlet of each subassembly. These measurements are essential to monitor the temperatures and powers released by each subassembly.

The leak tightness of the fuel pins is monitored by a measuring system which detects clad failures through gas analysis and which detects delayed neutrons. Detection is completed by a local analysis in order to locate the fuel subassembly involved.

As usual, the fuel subassemblies are surrounded radially by fertile subassemblies containing depleted uranium, this uranium being a waste product from uranium enrichment plants. The transformation of uranium 238 into plutonium 239 makes it possible to produce more plutonium than the quantity consumed in the core; this is the principle of breeding.

The cores of current design are not aimed at breeding but at stabilising the plutonium inventory, without using fertile subassemblies.



REFERENCES 91

REFERENCES

REFERENCES OF CHAPTER 2:

1. F. Storrer, "Summary of the experience feedback of SFRs in France", Technical Memo CEA DPIE/SA2P 160RNRNA12MWA.
2. A. Vasile and al., "Document of analysis of foreign SFR concepts", Technical Memo CEA DEN/CAD/DE/Dir No. 2011/2012.
3. N. Devictor and al., "Elements for comparison of loop-type and pool-type reactor designs (LR2)", DER/CAD/ NT DO 2012-16, late 2011.
4. J. Guidez, L. Martin, G. Giraud, JS. Sauvage, "Summary of the operation of sodium-cooled fast reactors throughout the world", RGN No. 3, May-June, 2010.

REFERENCES OF CHAPTER 3:

1. B. Fontaine, "Summary of the studies on carbide cores for SFRs within the scope of a safety action during design (COCONS approach)", Technical report CEA/DEN/CAD/DER/SPRC/LEDC/12-402 (2012).
2. P. Richard and al., "Summary of the oxide core studies (SFRv2 and CFV) - CFV core qualification programme", Technical report CEA/DEN/CAD/DER/SESI/LC4G.
3. "Cycle of carbide fuels", Technical Memo CEA DRCP/SE2A/2011/16.
4. S. Raboin and al., "Summary of the R&D studies related to safety improvement", Technical report CEA/DEN/CAD/SESI/LC4G DR01.

REFERENCE OF CHAPTER 5:

1. JP. Grouiller, "Transmutation in the Astrid prototype (LR2)", Technical Memo CEA DEN/CAD/DER/CPA AST1 NT 0075 issue 2.

REFERENCES OF CHAPTER 6:

1. JPh. Jeannot, "Summary of the core monitoring studies (LR2)", DTN/STPA/LIET/NT 2012/041.
2. MS. Chenaud, F. Morin, "Summary of the R&D studies on pool type SFR primary vessels", CAD/DER/SESI/ LC4G/RT DR03.

3. L. Cachon, "Summary of the studies on gas power conversion systems (LR2)", DTN/STPA/LCIT NT 2012/No. 027.
4. N. Devictor et al, "Elements for comparison of loop-type and pool-type reactor designs (LR2)", DER/CAD/ NT DO 2012-16, late 2011.
5. G. Rodriguez, "Power conversion system with alternative fluid (LR2)", Technical Memo DTN/DIR 02.
6. G.Laffont, G. Rodriguez, "Water-steam power conversion system – Summary of studies (modular concept, technology, instrumentation) / (LR2)", Technical Memo DER/CPA 0079 issue 1.
7. F. Baqué, G. Rodriguez, "Summary of ISIR without core monitoring (LR2)", DTN/STPA/LIET/NT 2012/038.
8. Ph. Dubuisson et al., "ODS Ferritic/martensitic alloys for sodium fast reactor fuel pin cladding", Journal of Nuclear Materials 2011.

REFERENCES OF CHAPTER 7:

1. Masson, "Reprocessing of fuels from fast breeder reactors: summary of the situation, R&D", Technical Memo DRCP 2012/DR 1.
2. F. Gobin, "Technological orientations for FBR fuel processing", DTEC/SGCS/NT-2011-04.

REFERENCES OF CHAPTER 8:

1. C. JOURNEAU, J.M. RUGGIERI, P. PILUSO, "Plans for a new large scale corium facility at CEA-Cadarache: the FOURNAISE project", article published during the ERM-SAR 2012 conference (European Review Meeting on Severe Accident Research), Cologne, Germany, March 2012.
2. JL. Courouau, F. BalbaudCélérier, V. Lorentz, T. Duffrenoy, "Corrosion by liquid sodium of materials for sodium fast reactors: the CORRONa testing device", Proceedings of ICAPP 2011, Nice, France, May 25, 2011.
3. C. Latgé and al, "ADRIANA: present situation and future SFR needs; Deliverable D2.1".
4. C. Latgé and al, "ADRIANA: Final WP2 report on future needs and infrastructure road map supporting SFR development. Deliverable D2.2".

Design and edition: **avantgarde**
Photo credits: AREVA NP, CEA, GIF

